

General Product Information

This product is suitable for indoor dry and damp locations only.

Junction Box Requirements: This product is to be installed to a standard 4" junction box with 3" round plaster ring or an octagon junction box. It is the installer's responsibility to ensure that the site conditions, junction box, and fasteners used are suitable to support the weight of the fixture.

Driver to be housed in the canopy. Can be remote if necessary.

Fixture can be dimmed with TRIAC, ELV, or 0-10V dimming at 120VAC input.
For 240 or 277 VAC input, fixture is only dimmable with 0-10V dimming.

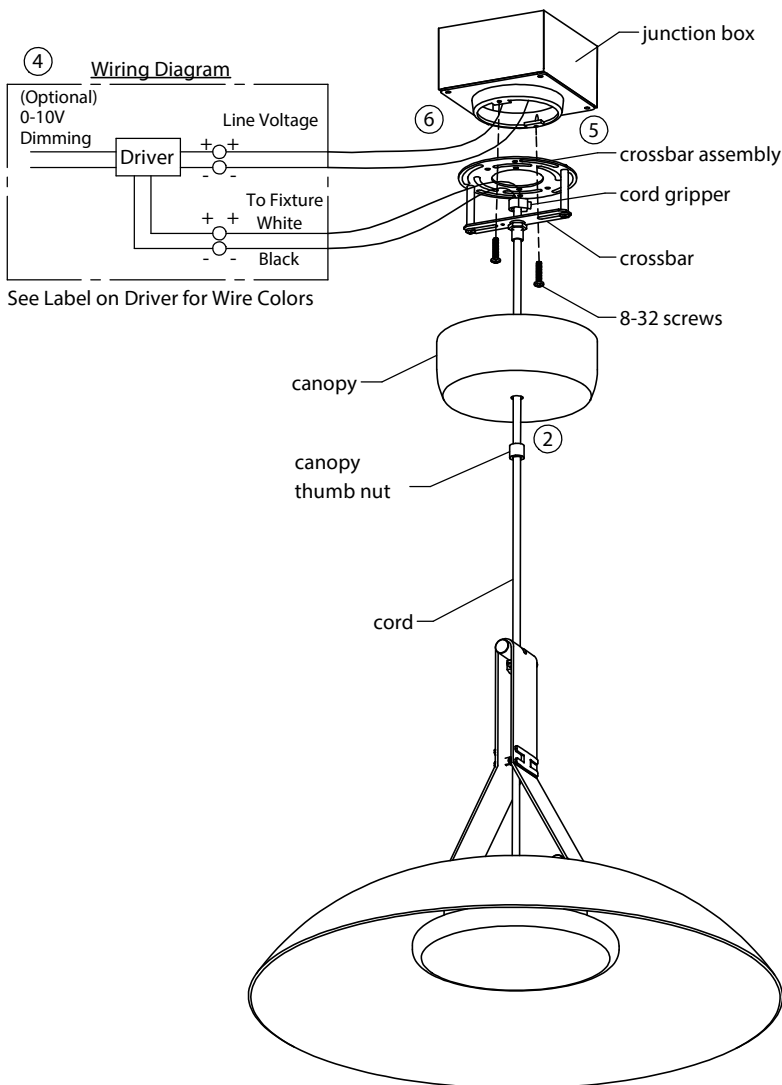
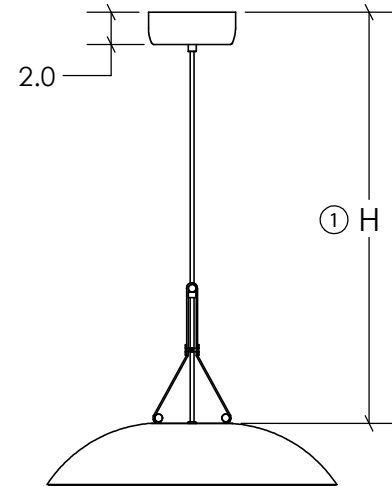

See Label on Driver for Wire Colors

CAUTION - RISK OF FIRE

This product requires installation by a qualified electrician. Before installing be sure to read all instructions and **TURN POWER OFF TO THE JUNCTION BOX**

- ① Measure the desired height (H) that you want the fixture to hang below the ceiling.
- ② Thread the cord through the canopy thumb nut, canopy, crossbar, and cord gripper.
- ③ Tighten the set screw on the cord gripper onto cable at desired height (H) using a small flathead screw driver. As an added safety measure, tie a knot in the cable above the cord gripper.
- ④ Make electrical connections as shown in the image to the left using the supplied wire nuts.

CRITICAL NOTE: If 0-10V dimming control is to be used, connect purple and pink driver leads to 0-10V dimmer. Otherwise, the tinned ends of these leads should be snipped off and the leads should be capped individually such that they remain isolated from one another.

- ⑤ Attach the crossbar assembly to the junction box using the supplied #8-32 screws.
- ⑥ After electrical connections have been made, place wire connections and excess wire into the junction box.
- ⑦ Slide the canopy up the cable and secure it by screwing the thumb nut onto the crossbar assembly.

