

Mica L Pendant E26 Socket

Installation Instructions

cerno®

General Product information



This product is suitable for indoor dry locations only.

This product is to be installed to a standard 4" junction box with a 3" round plaster ring or an octagon junction box.



CAUTION - RISK OF FIRE



This product requires installation by a qualified electrician. Before installing be sure to read all instructions and **TURN POWER OFF TO THE JUNCTION BOX**

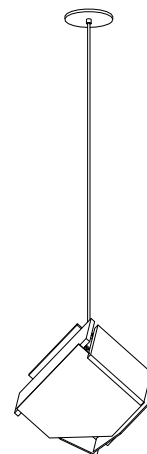

Adjusting the Fixture Height

- 1 Measure the desired height (H) you want the fixture to hang below the ceiling.
- 2 Thread the power cord through the diffuser shade assembly, thumb nut, canopy, crossbar assembly and cord grip.
- 3 Tighten cord grip at the desired length H, then tie a knot in cord above grip.

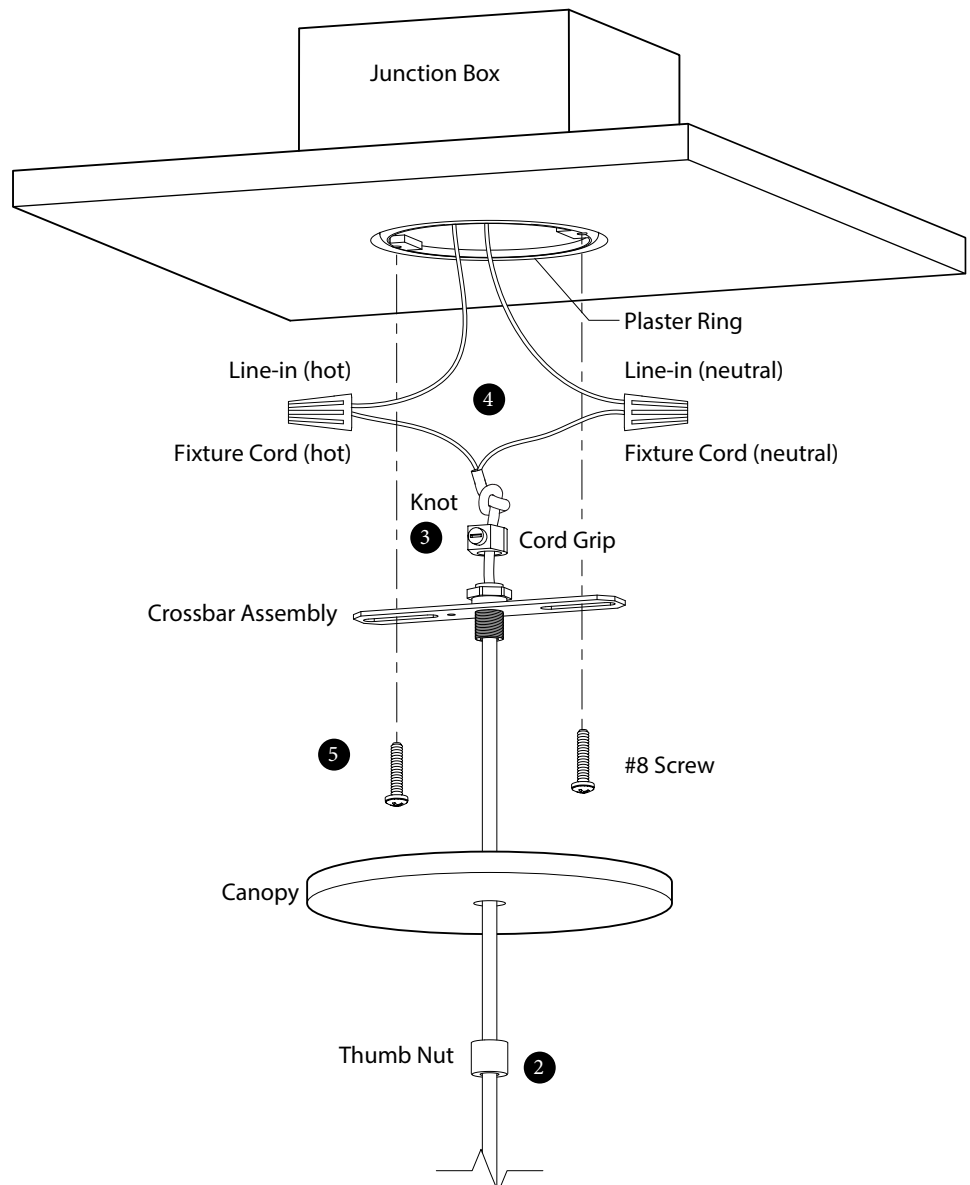
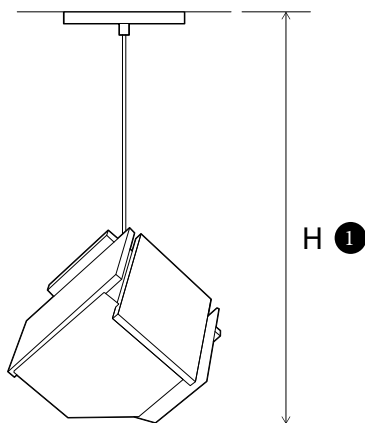

Making Electrical Connections

- 4 Make electrical connections as shown using the supplied wire nuts.

Mounting the Fixture

- 5 Attach the crossbar to the junction box using the supplied #8 screws.

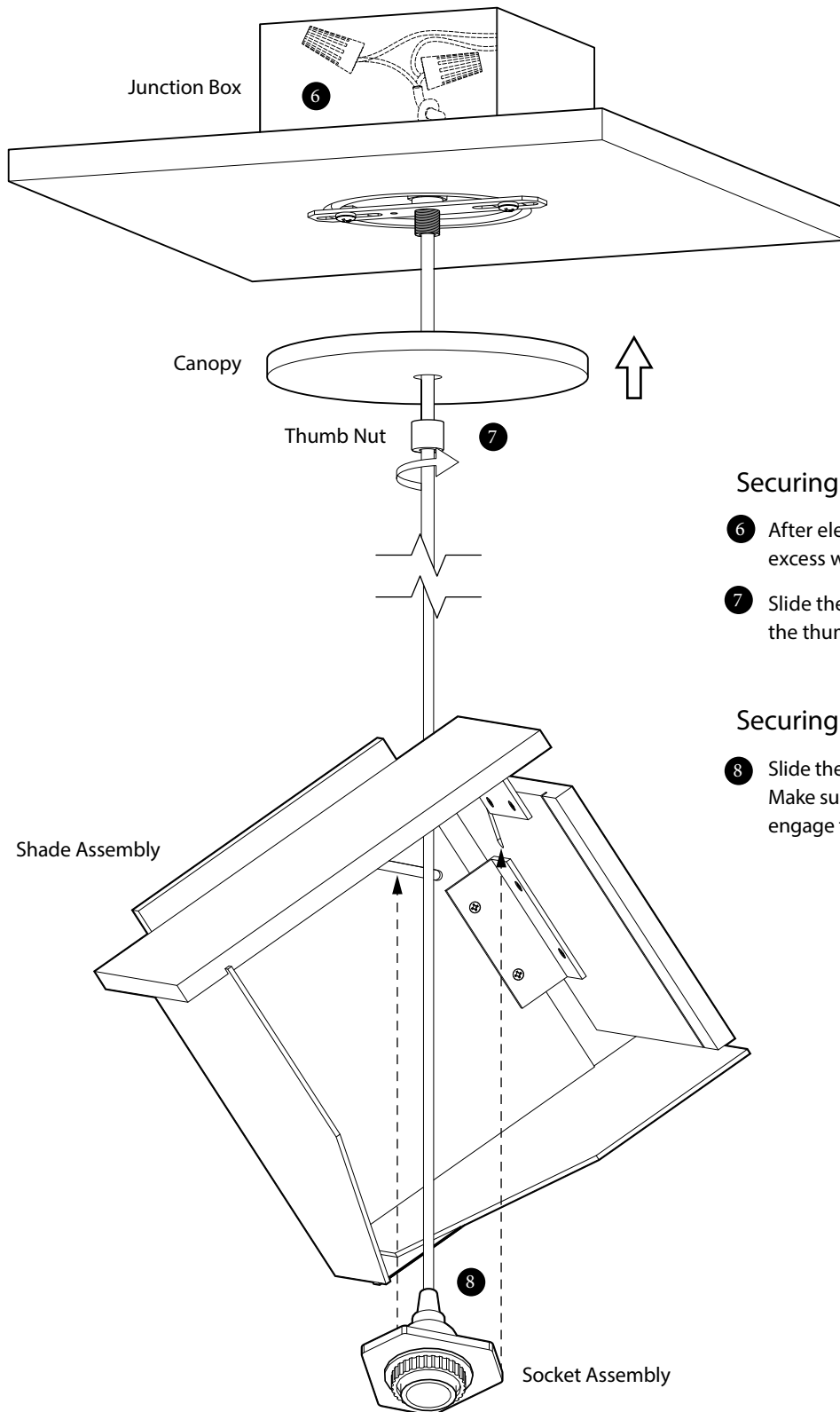

Securing the Canopy

- 6 After electrical connections have been made, place all excess wires inside of the junction box.
- 7 Slide the canopy up the cable and secure by screwing the thumb nut into the crossbar.

Securing the Shade

- 8 Slide the shade assembly down over the socket assembly. Make sure to align the shade assembly internal slots to engage the socket assembly.