

General Product information

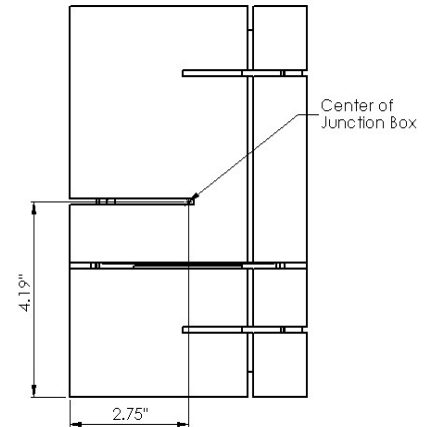

This product is suitable for indoor dry locations only.

This product is to be installed to a standard 4" junction box with 3" round plaster ring or an octagon junction box.

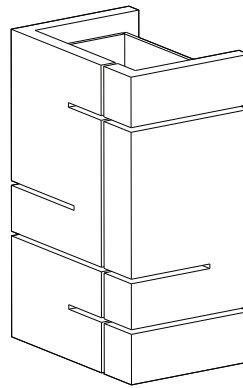

CAUTION - RISK OF FIRE



This product requires installation by a qualified electrician. Before installing be sure to read all instructions and **TURN POWER OFF TO THE JUNCTION BOX**

Installing the Mounting Plate

- 1 Attach the mounting plate to the junction box using the supplied #8-32 screws. Orient and level the plate as shown in the figure.
- 2 Attach a suitable ground wire to the green screw in the mounting plate.

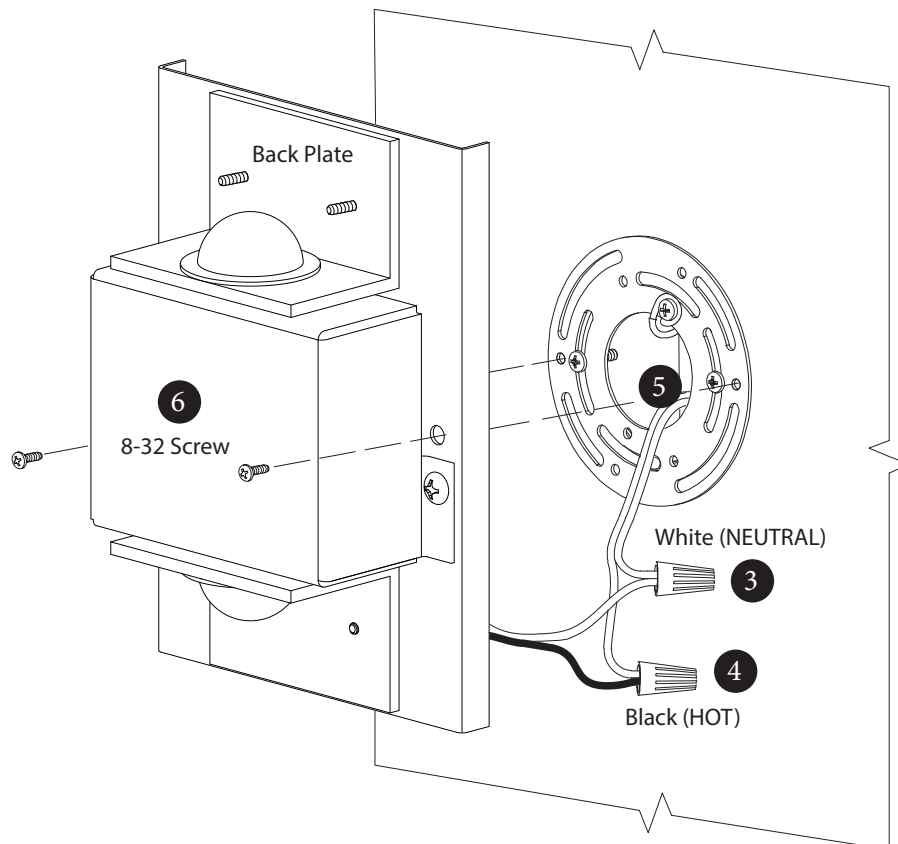
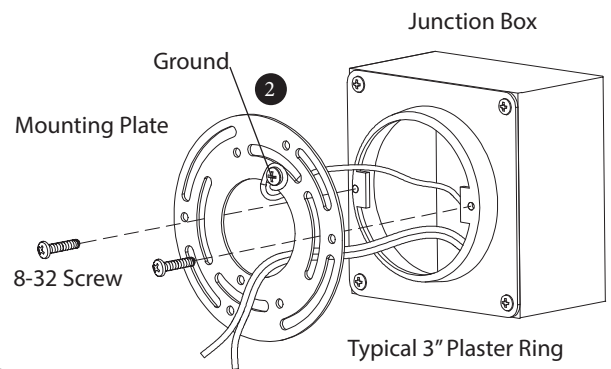

Attaching the Back Plate

- 3 Connect the white fixture wire to the neutral power line with a wire nut.
- 4 Connect the black fixture wire to the hot power line with a wire nut.
- 5 Place all wires in the junction box.
- 6 Mount the back plate to the mounting plate using the supplied #8-32 screws.

Attaching the Shade

- 7 Slide the shade onto the threaded screws protruding from the back plate.
- 8 Tighten the sconce shade against the light engine with provided thumb nuts.

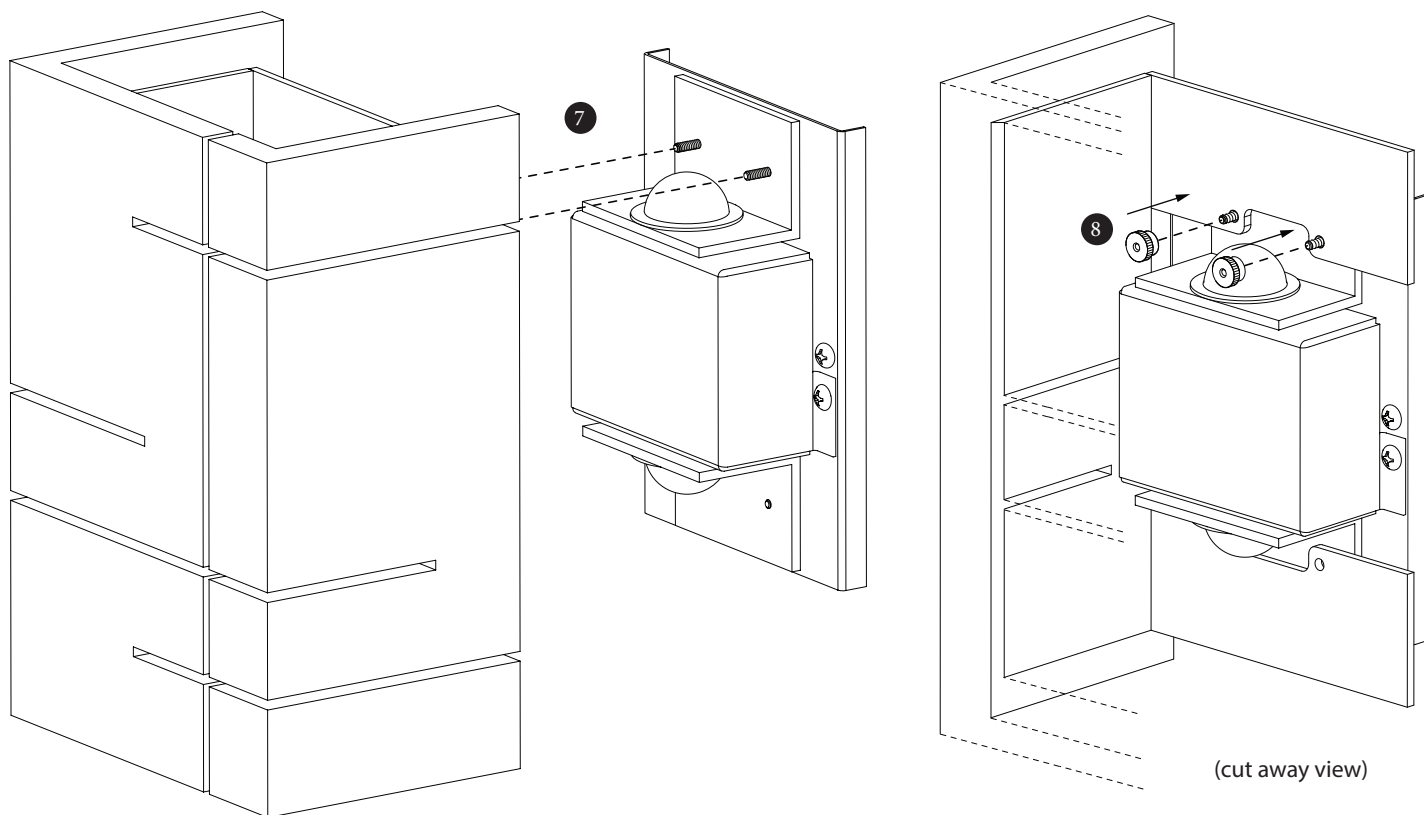

Important Note!

This fixture comes with a universal driver that can operate within an input voltage range of 120 and 277 V AC. See the table below to understand which types of dimming are available for a particular input voltage.

Input Voltage	Dimming Type
120	Triac, ELV, and 0-10V
240	0-10V only
277	0-10V only

The purple and grey leads exiting from the LED driver are there to enable dimming of the fixture through the use of a compatible 0-10V dimmer. If the fixture is to be dimmed using a 0-10V dimmer, follow the wiring instructions provided with the dimmer.

If the fixture is NOT to be dimmed using a 0-10V dimmer, the tinned ends of these leads should be snipped off and the leads should be capped individually such that they remain isolated from one another.

The wiring diagram below only applies if the fixture is to be controlled by a 0-10V dimmer.

