

cerno®



DESIGNED AND MADE IN CALIFORNIA



BELIEF

With no backyards but access to beaches and idyllic doses of salt and sun, our business story began with the adventures of three boys. Laguna Beach's creative culture and natural environment shaped our professional and aesthetic ideals. Looking back it's now clear that our childhood projects and experiments grew into our best adventure yet: building Cerno.

THE BEGINNING



Cerno founders, 1998. Left to right: Nick Sheridan, Dan Wacholder, Bret Englander.

Our drive and influences come from many different sources. One source that influenced all of us is Daniel's late grandfather, Steve. Steve grew up on a remote homestead where the existence of most objects depended on people's ability to create and fix them. For all of his 101 years, he embodied the saying "where there's a will, there's a way." On the California coast we were raised with this mentality and today we share it with the rest of the Cerno team.

CERNO

- Verb (Latin)

1. To resolve, distinguish, decide, sift, determine, to perceive.





Table of Contents

OUR TEAM

Each finished product is a celebration of the inventive minds and industrious hands that brought it to life. Dreams do not manifest themselves; skilled people bring dreams to life. The passion of our steadily growing team and their commitment to the product is inspiring. We are grateful for every individual that is part of our collaborative creative process.

Floor	9	Sconces	55
Fons 8 / Fons 10	10	Talea	57
Valeo	11	Via	58
Nauta Floor	14	Calx	59
Silva Floor	15	Penna Sconce	60
Forma	16	Vesper	61
Altus	17	Acuo	62
Silva Giant	18	Capio S	64
Linear Pendants	21	Capio L	64
Lenis	23	Tersus	68
Arca	24	Sedo	69
Camur	25	Ansa	71
Aeris 30 / Aeris 54	27	Fortis	72
Vix 34 / Vix 48	29	Claudo	73
Penna Pendant	30	Cubo	74
Vix 82	31	Libri	75
Virga	32	Levo	77
Brevis 28 / Brevis 42	33	Levo Shelf Option	77
Pendants	35	Table	79
Muto	36	Forma Table	80
Imber 17 / Imber 24	38	Nauta Table	81
Ignis 17 / Ignis 24	39	Silva	82
Ico	41	Macto	83
Calx 10 / Calx 19	42	Revelite AL	85
Calx 36	43	Accessories	86
Abeo	44	Motus Swing Arm Bracket	86
Claudo	45	Canopy Accessories	86
Mica	47	Finish and Material Options	87
Mica L	47		
Levis	48		
Levis L	48		
Salix	49		
Plura Pendant	51		
Plura Flush Mount	53		



Floor



Fons Family



Valeo



Silva Giant



Silva Floor



Forma



Altus

Fons 8 / Fons 10
floor

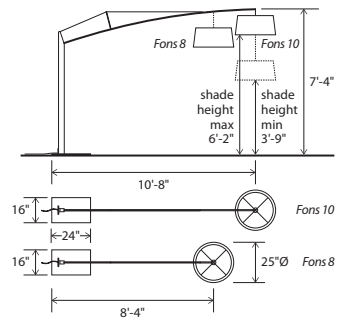

Dimensions: 25" Ø shade, 7'-4"
 Materials: solid wood, metal, linen shade
 Product weight: 65 lb
 Light source: medium base E26 socket
 Lamping: E26 base, type A lamp, 60 W max
 Input voltage: 120 V AC max
 Includes 6'-0" clear silver cord with inline foot switch 24" from base
 Bottom diffuser included (CM-051)
 Wood grain will vary
 Specifications subject to change



Included dimmable LED A19 bulb
 Light output: 800 Lumens (source)
 Light color: 2700 K
 Color accuracy: 90+
 Power usage: 11 W

MATERIAL & FINISH OPTIONS

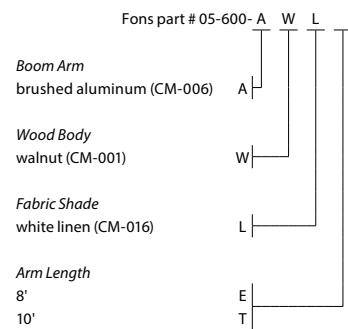

Includes
 stainless steel tension cable (CM-053)
 black powder coated steel base (CM-049)
 frosted polymer diffuser (CM-051)

Alternate voltage/plug styles are available



ARM LENGTH
 Available in 10'-8" and 8'-4" arm lengths
 Arm length is from back of base to center of shade
 Arm lengths are not adjustable

SHADE HEIGHT
 Shade height (floor to bottom edge of shade) can be adjusted between 6'-2" maximum and 3'-9" minimum.

The goal with the Fons was to minimize the structure and visual massing of the fixture while maximizing the reach or cantilever. The delicate boom arm, upheld by a tension cable, gently bends while reaching out to almost horizontal where it suspends the light. The structural design is an extremely effective way to resolve the forces associated with such a long reach. It is so effective and efficient that it seems to float with a weightlessness at the tip.

Nick Sheridan
 Designer

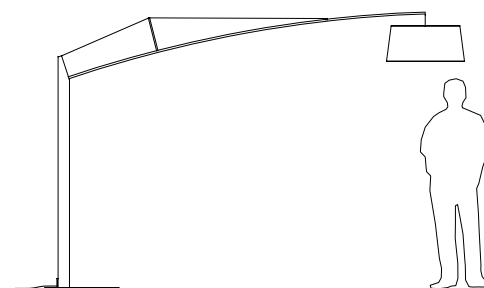

Valeo
floor

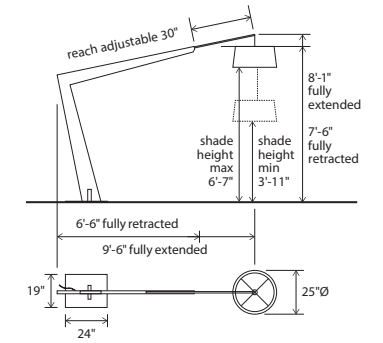

Dimensions: 8'1" H max, 25" Ø shade
 Materials: solid wood, metal, linen shade
 Product weight: 95 lb
 Light source: medium base E26 socket
 Lamping: E26 base, type A lamp, 60 W max
 Input voltage: 120 V AC max
 Includes 72" clear silver cord with inline foot switch 24" from base
 Bottom diffuser included (CM-051)
 Wood grain will vary
 Specifications subject to change



Included dimmable LED A19 bulb
 Light output: 800 Lumens (source)
 Light color: 2700 K
 Color accuracy: 90+ CRI
 Power usage: 11 W

MATERIAL & FINISH OPTIONS

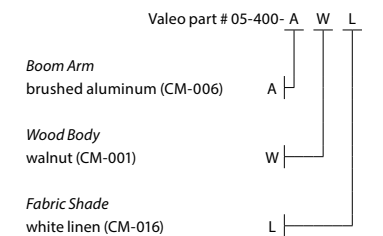

Includes
 black powder coated steel base (CM-049)
 frosted polymer diffuser (CM-051)

Alternate voltage/plug styles are available

When reaching such a distance with a fixture, it is important that it feels visually efficient in its form but is still far from fragile, inviting one to linger under it. The adjustability in the reach and the height of the shade make it possible to custom fit the piece to its surroundings - an important characteristic for such a large piece.

Nick Sheridan
 Designer

ARM LENGTH
 Arm length (from back of base to center of shade) can be adjusted between 9'-6" maximum and 6'-6" minimum.

SHADE HEIGHT
 Shade height (floor to bottom edge of shade) can be adjusted between 6'-7" maximum and 3'-11" minimum.

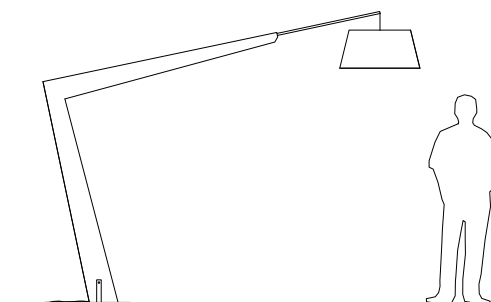



in collaboration with
DESIRON FRANK CARFARO
HAND CRAFTED AMERICAN FURNITURE

Nauta Floor
floor

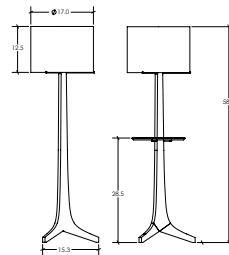

Dimensions: 17" Ø, 59"
Materials: solid wood, aluminum, fabric shade
Product weight: 8 lb
Light source: medium base E26 socket
Lamping: E26 base, 60 W max
Input voltage: 250 V AC max
Includes 8' clear silver cord with white plug
On/Off rocker switch on socket
Wood grain will vary
Specifications subject to change
SHELF IS OPTIONAL
UL
Included dimmable LED A19 bulb
Light output: 800 Lumens (source)
Light color: 2700 K
Color accuracy: 90+ CRI
Power usage: 11 W

MATERIAL & FINISH OPTIONS

Nauta Floor part #: 05-110-

Metal Finish

- brushed aluminum (CM-006) A
- brushed brass (CM-008)* R

Wood Body

- walnut (CM-001) W
- dark stained walnut (CM-002) D
- white washed oak (CM-095) O

Shade

- black amaretto (CM-018) A
- white linen (CM-016) L
- burlap (CM-017) N

Optional Shelf Accessory

- no shelf N
- matching wood shelf -
exposed wood top surface M
- matching wood shelf -
black HPL top surface (CM-092) B
- matching wood shelf -
white HPL top surface (CM-093) W

*Brass shade support arms feature wood plug in end of arm
**Shelf is optional and cannot be removed by customer



black amaretto (CM-018)



white linen (CM-016)



burlap (CM-017)

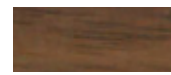

walnut (CM-001)

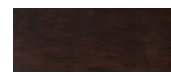

dark stained walnut (CM-002)



white washed oak (CM-095)



brushed brass (CM-008)



brushed aluminum (CM-006)



walnut, brushed aluminum, burlap

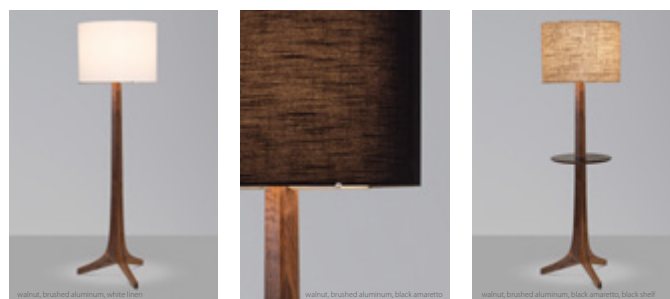

Efficiency and simplicity guided the design process for the Nauta table lamp. We designed the Forma several years ago with Frank Carfaro of Desiron, which profoundly influenced the Nauta's form. Our goal was to distill the Forma design without compromising it. The Nauta is clean, modern, and priced competitively.

Nick Sheridan
Designer

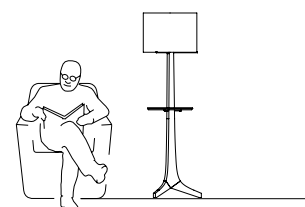

Silva Floor, walnut body, ebony eco veneer shade



The Silva Floor is slender, elegant, and poised while delivering great functionality. The tri-leg base finds stability on uneven surfaces and allows the cord to exit discreetly and effectively. It feels signature and iconic while still keeping a clean and timeless modern aesthetic.

Nick Sheridan
Designer

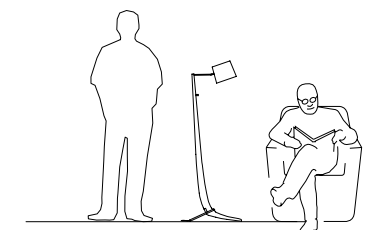

Silva Floor
floor

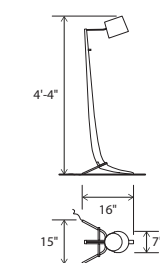

Dimensions: 16" x 15", 4'-4"
Materials: solid wood, aluminum, bent shade
Articulating head
Product weight: 4 lb
Light source: integrated LED
Light output: 565 Lumens (source)
Light color: 2700 K
Color accuracy: 90+ CRI
Power usage: 7 W
Input voltage: 12V DC (adapter included)
Includes 72" white braided cord
Dimmable on fixture
Wood grain will vary
Specifications subject to change
UL



beech wood veneer (CM-019)



ebony eco veneer (CM-020)



white linen (CM-058)

MATERIAL & FINISH OPTIONS

Silva Floor part # 05-100- A W

Metal Finish

- brushed aluminum (CM-006) A

Wood Body

- walnut (CM-001) W

Bent Shade

- beech wood veneer (CM-019) B
- ebony eco veneer (CM-020) E
- white linen (CM-058) L

Alternate voltage/plug styles are available
Also available in larger version, see page 14, and smaller version, see page 74.

in collaboration with
DESIRON FRANK CARFARO
HAND CRAFTED AMERICAN FURNITURE

Forma
floor

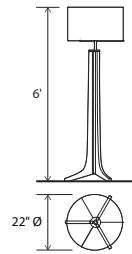

Dimensions: 22" Ø shade, 6'
Materials: solid wood, aluminum, fabric shade
Product weight: 15 lb
Light source: medium base E26 socket
Lamping: E26 base, type A lamp, 60 W max
Input voltage: 120 V AC max
Dimmable on fixture
Wood grain will vary
Specifications subject to change



Included dimmable LED A19 bulb
Light output: 800 Lumens (source)
Light color: 2700 K
Color accuracy: 90+ CRI
Power usage: 11 W

MATERIAL & FINISH OPTIONS

Forma Floor part # 05-300-

Metal Finish

- brushed aluminum (CM-006) A
- black anodized aluminum (CM-007) B

Wood Body

- walnut (CM-001) W
- dark stained walnut (CM-002) D
- maple (CM-005) M

Fabric Shade

- burlap (CM-017) N
- white linen (CM-016) L
- black amaretto (CM-018) A

Alternate voltage/plug styles are available
Also available in smaller version, see page 73.



Frank Carfaro and I worked to design a piece that embraced both Cerno and Desiron's aesthetic, without deviating too much from either brand's design language. I am really pleased with the fluidity, posture and scale we achieved with the Forma.

Nick Sheridan
Co-Designer

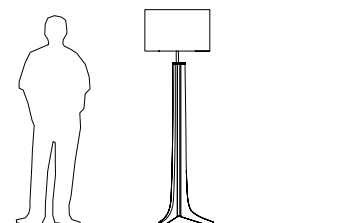

in collaboration with
DESIRON FRANK CARFARO
HAND CRAFTED AMERICAN FURNITURE

Altus
floor

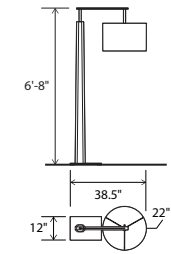

Dimensions: 6'-8" H, 22" Ø shade
Materials: solid wood, metal, fabric shade
Product weight: 45 lb
Light source: medium base E26 socket
Lamping: E26 base, type A lamp, 60 W max
120 V AC max
Dimmable on fixture
Wood grain will vary
Specifications subject to change



Included dimmable LED A19 bulb
Light output: 800 Lumens (source)
Light color: 2700 K
Color accuracy: 90+ CRI
Power usage: 11 W

MATERIAL & FINISH OPTIONS

Altus part # 05-700-

Metal Finish

- brushed brass (CM-008) R
- distressed brass (CM-009) D
- oiled bronze (CM-010) Z

Wood Body

- walnut (CM-001) W
- dark stained walnut (CM-002) D

Fabric Shade

- burlap (CM-017) N
- white linen (CM-016) L
- black amaretto (CM-018) A

Alternate voltage/plug styles are available

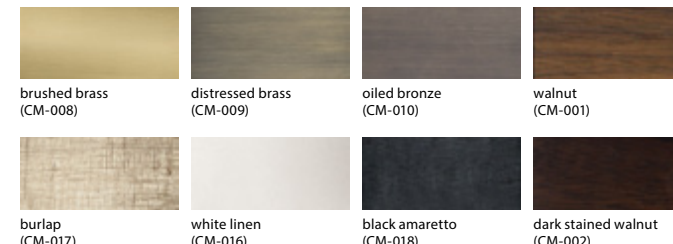

The Altus is a robust fixture that also carries an air of elegance and subtle proportion. It has the mass and impact to anchor a space while still showing balance and grace. It is always exciting to see how the solid wood trunk comes out; admiring the wood grain all the way through.

Nick Sheridan
Co-Designer

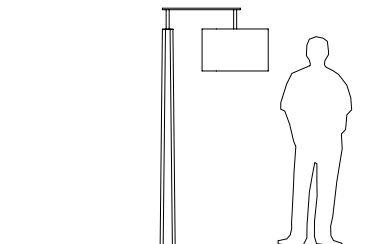

Silva Giant
floor

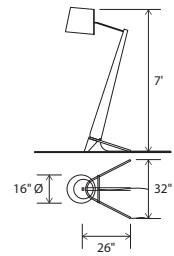

Dimensions: 32" x 26", 7", 16" Ø shade
 Materials: solid wood, aluminum, linen shade
 Product weight: 60 lb
 Light source: medium base E26 socket
 Lamping: E26 base, type A lamp, 60 W max
 Input voltage: 120 V AC max
 Includes 72" clear silver cord with inline foot switch 24" from base
 Bottom diffuser included (CM-057)
 Wood grain will vary
 Specifications subject to change

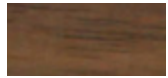

walnut (CM-001)

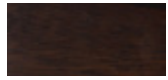

dark stained walnut (CM-002)



Included dimmable LED A19 bulb
 Light output: 800 Lumens (source)
 Light color: 2700 K
 Color accuracy: 90+ CRI
 Power usage: 11 W

MATERIAL & FINISH OPTIONS

	Silva Giant part # 05-200-	A	L
Metal Finish			
brushed aluminum (CM-006)		A	
Wood Body			
walnut (CM-001)		W	
dark stained walnut (CM-002)		D	
Fabric Shade			
white linen (CM-058)			L

Alternate voltage/plug styles are available
 Also available in 2 smaller versions
 See pages 15 and 74.



Silva Giant, brushed aluminum, walnut body, white linen shade

The Silva Giant, as the name suggests, is a giant version of our Silva table fixture. Its scale gives it a strong presence even in very large spaces, while its distilled form gives it a simplicity that can be seen from across the room. A fun piece with a huge personality.

Nick Sheridan
 Designer

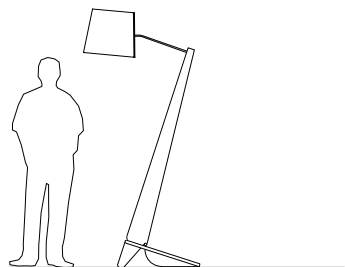

Linear Pendants

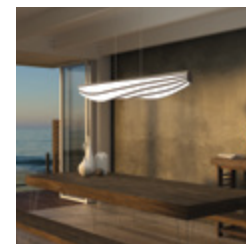

Lenis



Lenis

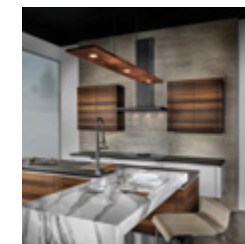

Vix



Vix

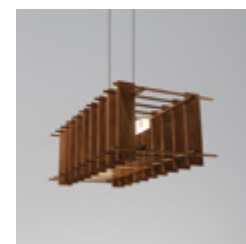

Arca



Camur



Vix 82

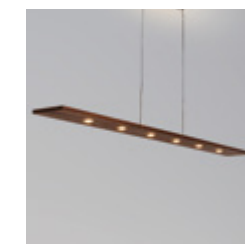

Vix 82



Penna Pendant



Aeris



Virga



Brevis





Bret, Dan and I have always loved the ocean and boats. In fact, the first project we built together as young boys was a sailboat. Our appreciation for the beauty of a well-designed craft is what initially inspired the Lenis fixture; the form is created by bending wood stringers over a series of bulkheads. The organic and sculptural structure deviates from our mostly rectilinear forms, which introduced many new challenges, yet it also breathed new life into the design process for us. Ultimately, we were searching for that balance between the curved fluidity of its lines and the twisting movement. Thanks to our team's determination, after countless studies and prototypes, we found the balance we were looking for.

Nick Sheridan,
Designer

Lenis
linear pendant

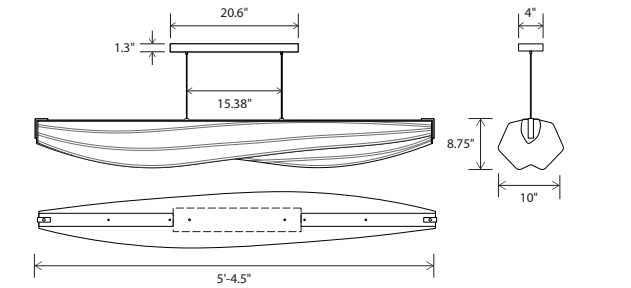

Dimensions: 5'-4.5" x 10", 8.75"
 Materials: aluminum, stretch fabric
 Product weight: 10 lb
 Light source: integrated LED
 Light output: 5000 Lumens (source)
 Light color: 2700 K or 3500 K
 Color accuracy: 90+ CRI
 Power usage: 70 W
 Dimmable (see driver below)
 Brushed Aluminum (CM-006)
 linear canopy included
 Canopy dimensions: 20.6" x 4", 1.3"
 Wood canopy covers are available:
 Walnut (CM-001) cover:
 part # 60-130-005W
 Dark stained walnut (CM-002) cover:
 part # 60-130-005D
 See website for more canopy information
 72" drop length, field adjustable
 Suitable for a sloped ceiling
 Wood grain will vary
 Specifications subject to change
 Patent pending



MATERIAL & FINISH OPTIONS

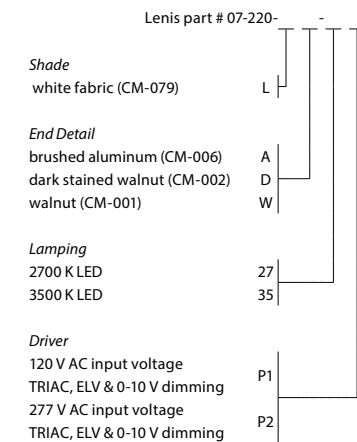

Includes
brushed aluminum (CM-006)

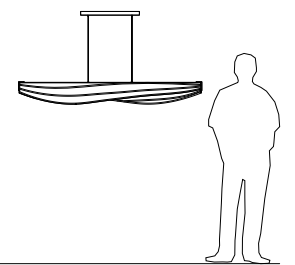
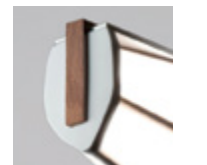
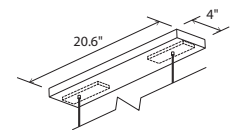

Arca
linear pendant

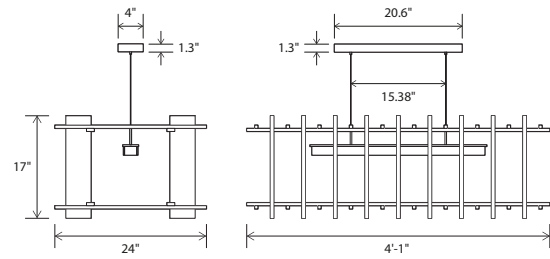

Dimensions: 4'-1" x 24", 17"
 Materials: solid wood, aluminum, polymer
 Product weight: 20 lb
 Light source: integrated LED
 Light output: 1720 Lumens (source)
 Light color: 2700 K or 3500 K
 Color accuracy: 90+ CRI
 Power usage: 16 W
 Dimmable (see driver below)
 Linear canopy included
 Canopy dimensions: 20.6" x 4", 1.3"
 Canopy finish matches fixture's metal finish
 Wood canopy covers are available:
 Walnut (CM-001) cover: part # 60-130-005W
 Dark stained walnut (CM-002) cover: part # 60-130-005D
 See website for more canopy information
 72" drop length, field adjustable
 Suitable for a sloped ceiling
 Wood grain will vary
 Specifications subject to change

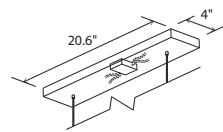

linear canopy, brushed aluminum



brushed aluminum (CM-006)



black anodized aluminum (CM-007)

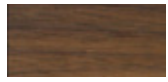

walnut (CM-001)

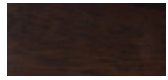

dark stained walnut (CM-002)

MATERIAL & FINISH OPTIONS

Arca part # 07-120-

Metal Finish	A	brushed aluminum (CM-006)
	B	black anodized aluminum (CM-007)
Wood Body	W	walnut (CM-001)
	D	dark stained walnut (CM-002)
Lamping	27	2700 K LED
	35	3500 K LED
Driver	P1	120-277 V AC input voltage 0-10V dimming TRIAC and ELV dimming at 120 V AC only

Includes
 polymer shade (CM-052)
 frosted acrylic diffuser (CM-024)

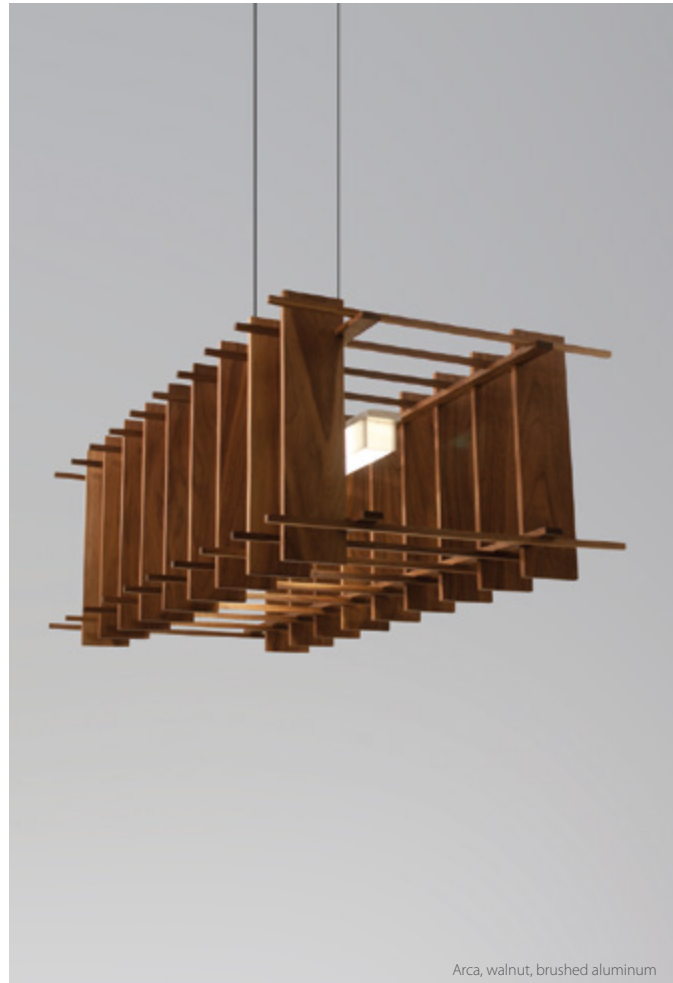

Arca, walnut, brushed aluminum

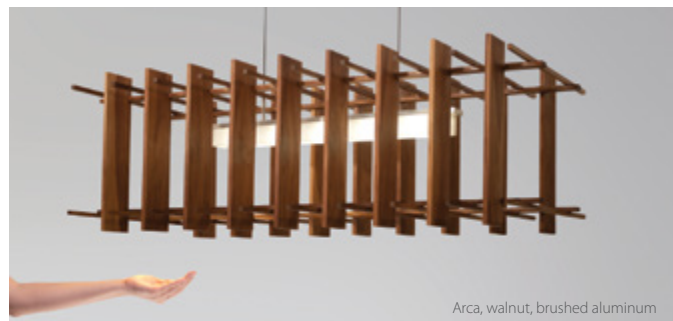

Arca, walnut, brushed aluminum

The Arca is an experiment with density and mass. As one moves around the room, the fixture morphs from a commanding presence of solid walnut into a graceful bar of light surrounded by an elegant porous cage.

Nick Sheridan
Designer

Camur
linear pendant

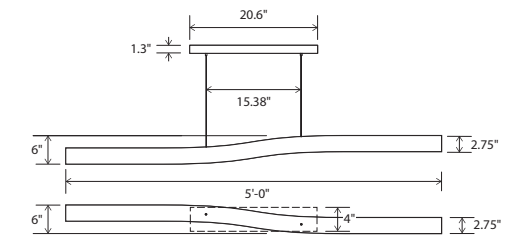

Dimensions: 5'-0" x 2.75", 2.75"
 Materials: solid wood, polymer
 Product weight: 6 lb
 Light source: integrated LED
 Light output: 2500 Lumens (source)
 Light color: 2700 K or 3500 K
 Color accuracy: 90+ CRI
 Power usage: 35 W
 Dimmable (see driver below)
 Brushed aluminum (CM-006) camur canopy included
 Canopy dimensions: 20.6" x 4", 1.3"
 Wood camur canopy covers are available:
 Walnut (CM-001) wood camur canopy cover: part # 60-150-005W
 Dark stained walnut (CM-002) wood camur canopy cover: part # 60-150-005D
 See website for more canopy information
 72" drop length, field adjustable
 Suitable for a sloped ceiling
 Wood grain will vary
 Specifications subject to change

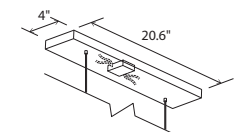

Camur canopy, brushed aluminum



Camur canopy cover, walnut

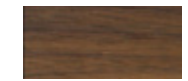

walnut (CM-001)

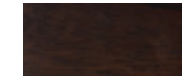

dark stained walnut (CM-002)

MATERIAL & FINISH OPTIONS

Camur part # 07-210-

Wood Body	W	walnut (CM-001)
	D	dark stained walnut (CM-002)
Lamping	27	2700 K LED
	35	3500 K LED
Driver	P1	120 V AC input voltage TRIAC, ELV & 0-10V dimming
	P2	277 V AC input voltage TRIAC, ELV & 0-10V dimming

The true beauty of the Camur is difficult to appreciate in print. When experiencing this fixture in person you begin to see the subtlety and grace of its vertical and horizontal movements. As you walk around this fixture the shape will morph from a beautiful curve to a straight line. We have created a video to help celebrate these details at www.cernogroup.com/camur



Camur, walnut



Light and delicate, subtly unique while simple, the camur must be experienced to really be appreciated. The gentle curve appears from the bottom just the same as it does from the side: but the perspectives found between the two intrigue.

Nick Sheridan,
Designer

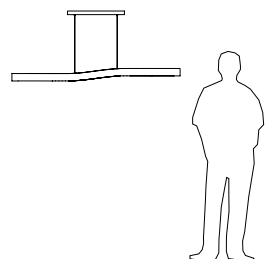
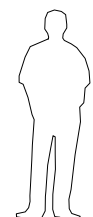

in collaboration with
DESIRON FRANK CARFARO
 HAND CRAFTED AMERICAN FURNITURE



The Aeris was a collaboration with New York based designer Frank Carfaro of Desiron. The organic and often wild swirls of walnut grain are interrupted by rigorous slits and inlays that punctuate each face to create a beautiful juxtaposition, making each fixture unique. The glow of the illuminated wood seen through the cut slits creates a rich composition of light and shadow.

Nick Sheridan
 Co-Designer

Aeris 30 / Aeris 54
 linear pendant

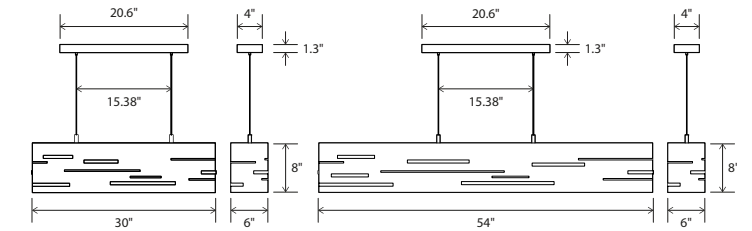

Aeris 30 dimensions: 30" x 6", 8"
 Aeris 54 dimensions: 54" x 6", 8"
 Materials: solid wood, aluminum
 Aeris 30 weight: 11 lb
 Aeris 54 weight: 15 lb
 Light source: integrated LED
 Light output - total: 1720 Lumens (source)
 Light output - downlight: 1030 Lumens (source)
 Light output - uplight: 690 Lumens (source)
 Light color: 2700 K or 3500 K
 Color accuracy: 90+ CRI
 Power usage: 16 W
 Dimmable (see driver below)
 Linear canopy included
 Canopy dimensions: 20.6" x 4", 1.3"
 Canopy finish matches fixture's metal finish
 Wood canopy covers are available:
 Walnut (CM-001) cover: part # 60-130-005W
 Dark stained walnut (CM-002) cover:
 part # 60-130-005D
 See website for more canopy information
 72" drop length, field adjustable
 Suitable for a sloped ceiling
 Wood grain will vary
 Specifications subject to change

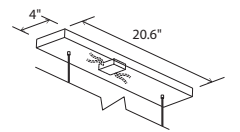

linear canopy,
 brushed aluminum



brushed aluminum
 (CM-006)



black anodized aluminum
 (CM-007)



walnut
 (CM-001)



dark stained walnut
 (CM-002)

MATERIAL & FINISH OPTIONS

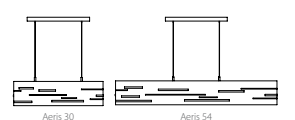
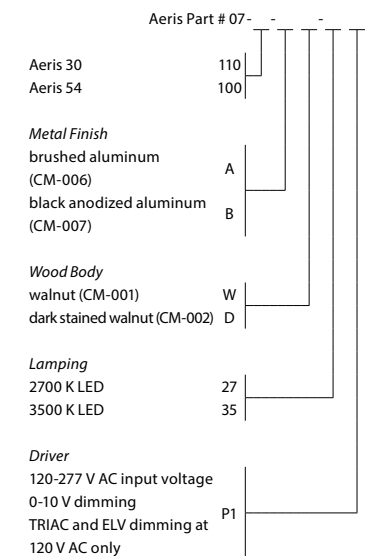

Includes
 polymer shade (CM-052)

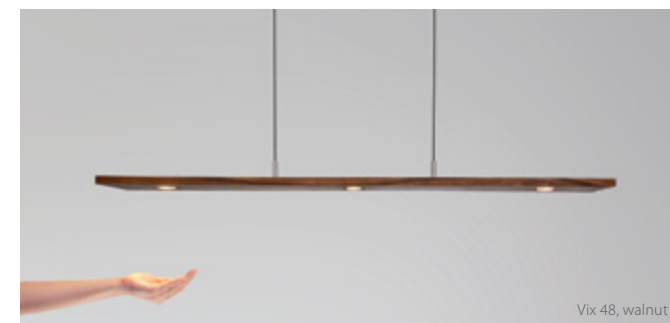

A clean, modern fixture finely executed. With multiple down and up lights, the Vix provides lots of usable light in a very unobtrusive design.

Nick Sheridan
Designer

Vix 34 / Vix 48
linear pendant

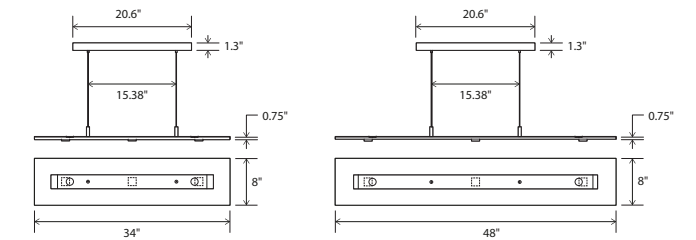

Vix 34 dimensions: 34" x 8", 0.75"
 Vix 48 dimensions: 48" x 8", 0.75"
 Materials: solid wood, polymer, aluminum
 Vix 34 weight: 10 lb
 Vix 48 weight: 15 lb
 Light source: integrated LED
 Light output - total: 1720 Lumens (source)
 Light output - downlight: 1030 Lumens (source)
 Light output - uplight: 690 Lumens (source)
 Light color: 2700 K or 3500 K
 Color accuracy: 90+ CRI
 Power usage: 16 W
 Dimmable (see driver below)
 Brushed aluminum (CM-006) linear canopy included
 Canopy dimensions: 20.6" x 4", 1.3"
 Wood canopy cover available:
 Walnut (CM-001) cover: part # 60-130-005W
 Dark stained walnut (CM-002) cover:
 part # 60-130-005D
 See website for more canopy information
 72" drop length, field adjustable
 Suitable for a sloped ceiling
 Wood grain will vary
 Specifications subject to change

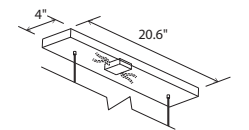

linear canopy,
brushed aluminum



walnut
(CM-001)



dark stained walnut
(CM-002)

MATERIAL & FINISH OPTIONS

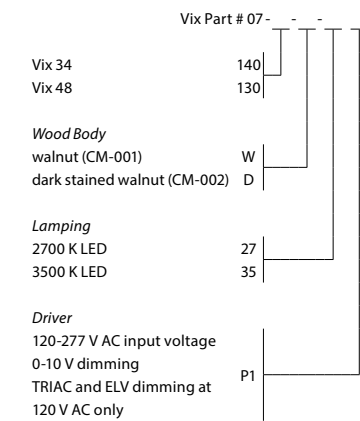

Includes
polymer shade (CM-052)

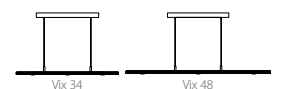

Penna 40 / Penna 64
linear pendant

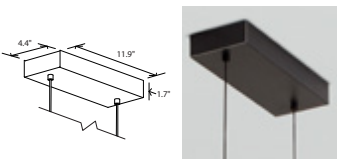
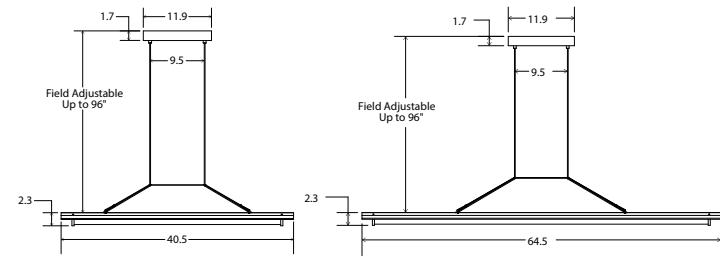

linear canopy,
matte black finish



brushed brass
(CM-008)

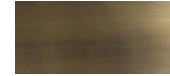

distressed brass
(CM-009)



walnut
(CM-001)



dark stained walnut
(CM-002)



brown leather
(CM-098)

Penna 40 dimensions: 40.5" x 7.7", 3.0"
Penna 64 dimensions: 64.5" x 7.7", 3.0"
Penna 40 weight: 7 lb
Penna 64 weight: 10 lb
Light source: integrated LED
Penna 40 light output: 1530 Lumens (source)
Penna 64 light output: 2550 Lumens (source)
Light color: 2700 K or 3500 K
Color accuracy: 90+ CRI
Penna 40 power usage: 21 W
Penna 64 power usage: 35 W
Dimmable (see driver below)
Linear canopy included
Canopy dimensions: 11.9" x 4.4", 1.7"
Canopy finish: matte black (CM-085)
See website for more canopy information
8"-0" drop length, field adjustable
Suitable for a sloped ceiling
Wood grain will vary
Specifications subject to change

MATERIAL & FINISH OPTIONS

Penna pendant part # 07-150-

	B	
Penna 40	40	
Penna 64	64	
Metal Finish		
brushed brass (CM-008)	R	
distressed brass (CM-009)	D	
Wood Body		
walnut (CM-001)	W	
dark stained walnut (CM-002)	D	
Lamping		
2700 K LED	27	
3500 K LED	35	
Driver		
120 V AC input voltage	P1	
TRIAC, ELV & 0-10 V dimming		
277 V AC input voltage	P2	
TRIAC, ELV & 0-10 V dimming		

Includes
brown leather (CM-098)
frosted polymer (CM-057)



Penna 64, walnut, brushed brass



Penna 64, walnut, distressed brass



Penna 40, dark stained walnut, distressed brass

On our Cerno journey, we continue to evolve as designers and craftsmen. The Penna is a celebration of us drawing and reflecting on our last ten years. This design is an embodiment of all the lessons that we have learned from designing and building thousands of lights. This fixture balances utility and sophisticated beauty well. The walnut, brass, and leather work in concert to compose a modern form with materials that have been used for thousands of years.

Nick Sheridan
Designer



Vix 82, walnut



Vix 82, walnut

A clean, modern fixture finely executed. With multiple down and up lights, the Vix provides lots of usable light in a very unobtrusive design.

Nick Sheridan
Designer

Vix 82
linear pendant

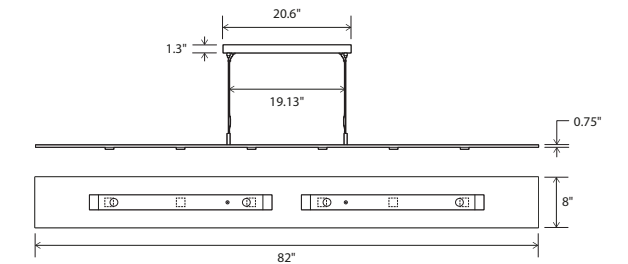

Dimensions: 82" x 8", 0.75"
Materials: solid wood, polymer, aluminum
Product weight: 19 lb
Light source: integrated LED
Light output - total: 3440 Lumens (source)
Light output - downlight: 2060 Lumens (source)
Light output - uplight: 1380 Lumens (source)
Light color: 2700 K or 3500 K
Color accuracy: 90+ CRI
Power usage: 32 W
Dimmable (see driver below)
Brushed aluminum (CM-006) linear canopy included
Canopy dimensions: 20.6" x 4", 1.3"
See website for more canopy information
Drop length field adjustable: 0'-10" min, 8'-0" max
Suitable for a sloped ceiling
Wood grain will vary
Wood shade may slightly bow or twist along 82" length
Specifications subject to change

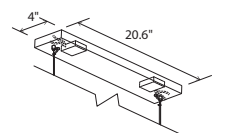

linear canopy,
brushed aluminum

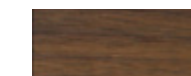

walnut
(CM-001)



dark stained walnut
(CM-002)

MATERIAL & FINISH OPTIONS

Vix 82 part # 07-200-

Wood Body		
walnut (CM-001)	W	
dark stained walnut (CM-002)	D	
Lamping		
2700 K LED	27	
3500 K LED	35	
Driver		
120-277 V AC input voltage		
0-10 V dimming		
TRIAC and ELV dimming at 120 V AC only	P1	

Includes
polymer shade (CM-052)

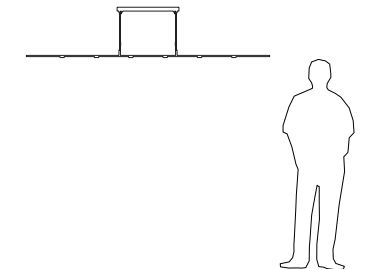

Virga
linear pendant

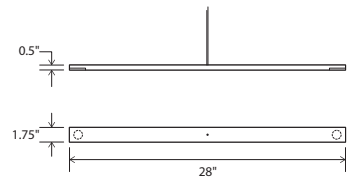

Dimensions: 28" x 1.75", 0.5"

Materials: aluminum, polymer

Product weight: 6 lb

Light source: integrated LED

Light output: 1126 Lumens (source)

Light color: 2700 K or 3500 K

Color accuracy: 90+ CRI

Power usage: 13 W

Dimmable (see driver below)

Extended-profile square canopy included,

required to house LED driver (3.25" x 2.25" x 1.25")

Canopy dimensions: 4.5" x 4.5", 1.63"

Canopy finish matches fixture's metal finish

See website for more canopy information

48" suspension tube (can be shortened in field)

Swivel option available for sloped ceilings,

see drawing below

Specifications subject to change

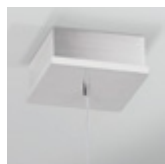
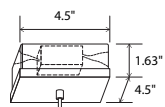

extended-profile square canopy
brushed aluminum



brushed aluminum
(CM-006)



black anodized aluminum
(CM-007)

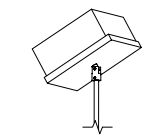

MATERIAL & FINISH OPTIONS

Virga part # 06-130-

Metal Finish

brushed aluminum (CM-006)

black anodized aluminum (CM-007)

Lamping

2700 K LED

3500 K LED

Driver

120-277 V AC input voltage

0-10V dimming

TRIAC and ELV dimming at

120 V AC only

Includes

polymer shade (CM-052)

Available for sloped ceilings:
Sloped Extended-Profile Square Canopy



Virga, brushed aluminum



Virga, black anodized aluminum

A clean, minimal fixture executed without compromise. The very simple and sleek down light bar can be installed in very close proximity to its user – and withstand close scrutiny.

Nick Sheridan
Designer

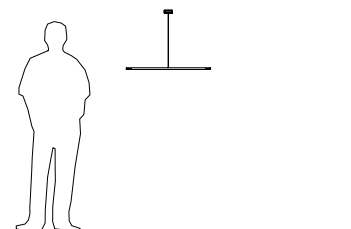

Brevis 28, brushed aluminum

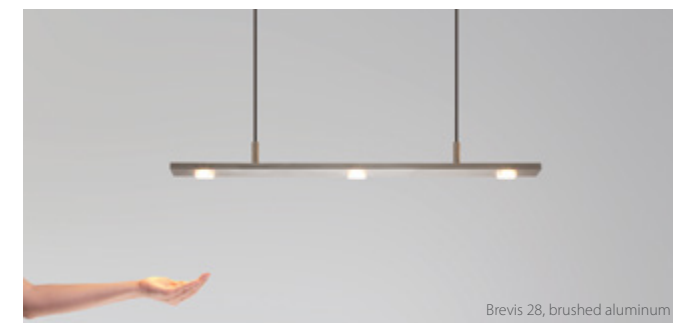

Brevis 28, brushed aluminum

A clean, minimal fixture finely executed. With multiple down and up lights, the Brevis provides lots of usable light in a very unobtrusive design

Nick Sheridan
Designer

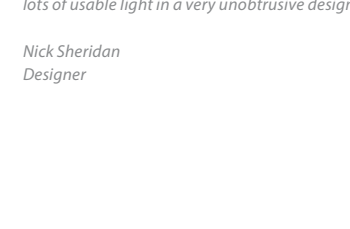

Brevis 28 / Brevis 42
linear pendants

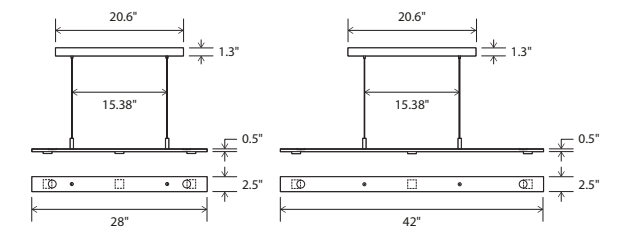

Brevis 28 dimensions: 28" x 2.5", 0.5"

Brevis 42 dimensions: 42" x 2.5", 0.5"

Materials: aluminum, polymer

Brevis 28 weight: 7 lb

Brevis 42 weight: 8 lb

Light source: integrated LED

Light output - total: 1720 Lumens (source)

Light output - downlight: 1030 Lumens (source)

Light output - uplight: 690 Lumens (source)

Light color: 2700 K or 3500 K

Color accuracy: 90+ CRI

Power usage: 16 W

Dimmable (see driver below)

Linear canopy included

Canopy dimensions: 20.6" x 4", 1.3"

Canopy finish matches fixture's metal finish

Wood canopy covers are available:

Walnut (CM-001) cover: part # 60-130-005W

Dark stained walnut (CM-002) cover:

part # 60-130-005D

See website for more canopy information

72" drop length, field adjustable

Suitable for a sloped ceiling

Specifications subject to change

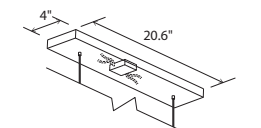

linear canopy,
brushed aluminum



brushed aluminum
(CM-006)



black anodized aluminum
(CM-007)

MATERIAL & FINISH OPTIONS

Brevis Part # 06-

Brevis 28

Brevis 42

Metal Finish

brushed aluminum

(CM-006)

black anodized aluminum

(CM-007)

Lamping

2700 K LED

3500 K LED

Driver

120-277 V AC input voltage

0-10 V dimming

TRIAC and ELV dimming at

120 V AC only

Includes

polymer shade (CM-052)

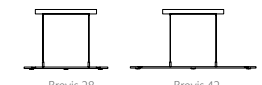

Brevis 28

Brevis 42

Pendants



Muto



Muto



Abeo

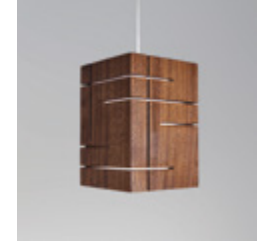

Claudo

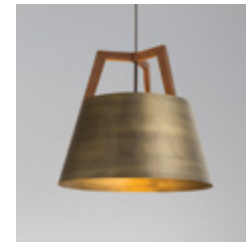

Imber

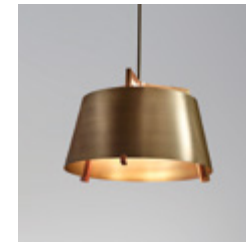

Ignis

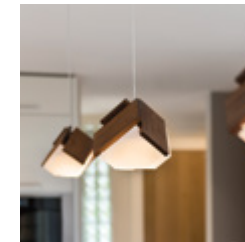

Mica



Mica Family



Ico

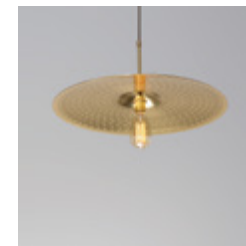

Ico



Levis Family



Salix

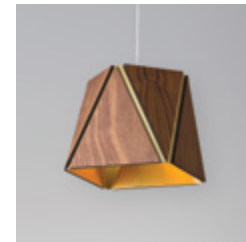

Calx 10/19



Calx 36

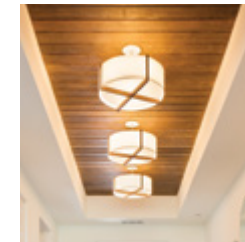

Plura Pendant



Plura Pendant



Muto
large pendant

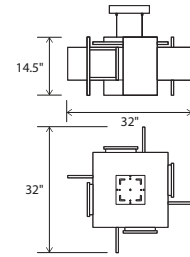

Dimensions: 32" x 32", 14.5"
 Materials: solid wood, polymer
 Product weight: 17 lb
 Light source: integrated LED
 Light output - total: 2626 Lumens (source)
 Light output - ambient: 1376 Lumens (source)
 Light output - downlight: 1250 Lumens (source)
 Light color: 2700 K or 3500 K
 Color accuracy: 90+ CRI
 Power usage: 25 W
 Dimmable (see driver below)
 Brushed aluminum (CM-006) 8" square canopy with black mesh cables included
 See instructions for additional canopy details at cernogroup.com
 72" drop length, field adjustable
 Suitable for a sloped ceiling
 Wood grain will vary
 Specifications subject to change

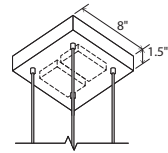

8" square canopy with black mesh cables



walnut (CM-001)



dark stained walnut (CM-002)

MATERIAL & FINISH OPTIONS

Muto part # 06-140-

Wood Body
 walnut (CM-001)
 dark stained walnut (CM-002)

Lamping

2700 K LED
 3500 K LED

Driver

120-277 V AC input voltage
 0-10 V dimming
 TRIAC and ELV dimming at 120 V AC only

Includes

frosted polymer diffuser (CM-024)



Muto, walnut



Muto, walnut



The way the walnut planes in the Muto both block and bounce light makes for a very dynamic composition of light and shadow, from any vantage point. While the pinwheel form with its repeating elements is symmetric, it appears very sculptural from any one view. The modern floating ideal is realized in the Muto. By holding each walnut element away from its neighbor, so each plane floats, the whole fixture feels weightless as if it were floating itself.

Nick Sheridan
 Designer



Muto, walnut

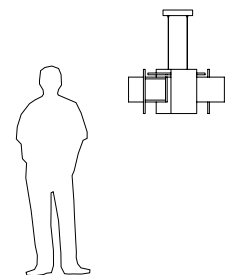

Imber 17 / Imber 24
pendant

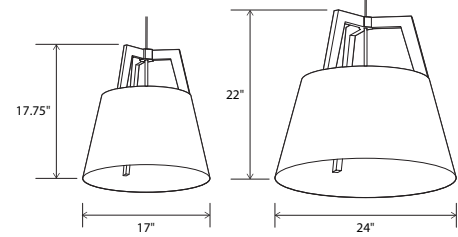

Imber 17 dimensions: 17" Ø, 17.75"
Imber 24 dimensions: 24" Ø, 22"
Materials: solid wood, metal
Imber 17 weight: 7 lb
Imber 24 weight: 12 lb
Wood grain will vary
Specifications subject to change

Lamping
Integrated LED Specifications
Light output: 1250 Lumens (source)
Light color: 2700 K
Additional color temperatures as well as sunset dimming are available upon request.
Color accuracy: 90+ CRI
Power usage: 13 W
Input voltage: 120-277 V AC
Dimmable: 0-10 V dimming at 120-277 V AC TRIAC and ELV dimming at 120 V AC only

Medium Base E26 Specifications
Imber 17 lamping:
1x E26 base, type A lamp, 75 W max
Imber 24 lamping:
3x E26 base, type A lamp, 75 W max each
Bulbs not included
Input voltage: 250 V AC max

Suspension Type
Corded
96" length of SVT wire is used. Wire is field adjustable and suitable for a sloped ceiling.
Rigid
Stem comes 6' long and is field cuttable to length (.038" Ø).

Suspension and Hardware Finish
Standard Combinations
Come with either black or satin nickel suspension, canopy, and sockets:
Black: DW, DD, RW, GD
Satin Nickel: AW, AM, WM
Corded Versions
White cord: satin nickel hardware
Black cord: black hardware
24" Imber corded uses a .06" Ø steel cable for suspension

MATERIAL & FINISH OPTIONS

Imber part # 06-210-	
Fixture Size	
17" Ø	17
24" Ø	24
Standard Combinations (Shade, Frame)	
distressed brass, walnut	DW
distressed brass, dark stained walnut	DD
brushed brass, walnut	RW
brushed aluminum, walnut	AW
brushed aluminum, maple	AM
brushed rose gold, dark stained walnut	GD
gloss white, maple	WM
Suspension Type	
corded	C
rigid	R
Lamping	
integrated LED with diffuser	L
medium base socket without diffuser	S
medium base socket with diffuser	D

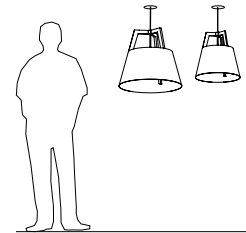

Diffuser
Frosted white diffuser (CM-024)
Diffuser is recommended when fixture location may allow for direct glare.
Integrated LED option always comes with a diffuser



Imber 24, distressed brass, walnut



distressed brass (CM-009) dark stained walnut (CM-002) DD	brushed brass (CM-047) walnut (CM-001) RW	brushed aluminum (CM-012) walnut (CM-001) AW
brushed aluminum (CM-012) maple (CM-005) AM	brushed rose gold (CM-046) dark stained walnut (CM-002) GD	gloss white (CM-054) maple (CM-005) WM

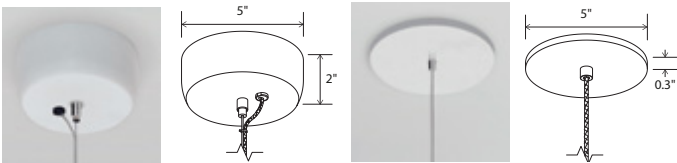

Imber/Ignis 24 with LED lamping
Extended-profile round canopy, braided cord with steel cable included, required to house the LED driver (3.25" x 2.25" x 1.25")
Canopy dimensions: 5.5"Ø, 2" deep

Imber/Ignis 17 with LED lamping
Low-profile round canopy, braided cord included
Canopy dimensions: 5"Ø, 0.3" deep



Ignis 24, brass, walnut



distressed brass (CM-009) dark stained walnut (CM-002) DD	brushed brass (CM-047) walnut (CM-001) RW	brushed aluminum (CM-012) walnut (CM-001) AW
brushed aluminum (CM-012) maple (CM-005) AM	brushed rose gold (CM-046) dark stained walnut (CM-002) GD	gloss white (CM-054) maple (CM-005) WM

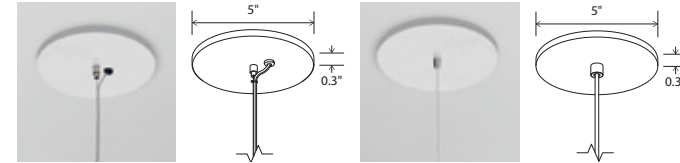

Imber/Ignis 24 with Medium base socket
Low-profile round canopy, SPT with steel cable
Canopy dimensions: 5"Ø, 0.3" deep

Imber/Ignis 17 with Medium base socket
Low-profile round canopy, SVT included
Canopy dimensions: 5"Ø, 0.3" deep

Ignis 17 / Ignis 24
pendant

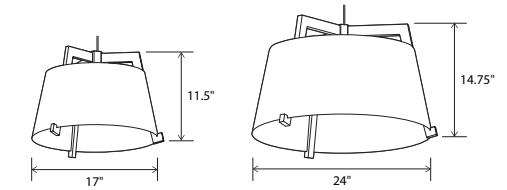

Ignis 17 dimensions: 17" Ø, 11.5"
Ignis 24 dimensions: 24" Ø, 14.75"
Materials: solid wood, metal
Ignis 17 weight: 7 lb
Ignis 24 weight: 11 lb
Wood grain will vary
Specifications subject to change

Lamping
Integrated LED Specifications
Light output: 1250 Lumens (source)
Light color: 2700 K
Additional color temperatures as well as sunset dimming are available upon request.
Color accuracy: 90+ CRI
Power usage: 13 W
Input voltage: 120-277 V AC
Dimmable: 0-10 V dimming at 120-277 V AC TRIAC and ELV dimming at 120 V AC only

MATERIAL & FINISH OPTIONS

Ignis part # 06-220-	
Fixture Size	
17" Ø	17
24" Ø	24
Standard Combinations (Shade, Frame)	
distressed brass, walnut	DW
distressed brass, dark stained walnut	DD
brushed brass, walnut	RW
brushed aluminum, walnut	AW
brushed aluminum, maple	AM
brushed rose gold, dark stained walnut	GD
gloss white, maple	WM
Suspension Type	
corded	C
rigid	R
Lamping	
integrated LED with diffuser	L
medium base socket without diffuser	S
medium base socket with diffuser	D

Medium Base E26 Specifications
Ignis 17 lamping:
1x E26 base, type A lamp, 75 W max
Ignis 24 lamping:
3x E26 base, type A lamp, 75 W max each
Bulbs not included
Input voltage: 250 V AC max

Suspension Type
Corded
8'-0" length of SVT wire is used. Wire is field adjustable and suitable for a sloped ceiling.
Rigid
Stem comes 6' long and is field cuttable to length (.038" Ø)

Suspension and Hardware Finish
Standard Combinations
Come with either black or satin nickel suspension, canopy, and sockets:
Black: DW, DD, RW, GD
Satin Nickel: AW, AM, WM
Corded Versions
White cord: satin nickel hardware
Black cord: black hardware
24" Ignis corded uses a 1/16" Ø steel cable for suspension

Diffuser
Frosted white diffuser (CM-024)
Diffuser is recommended when fixture location may allow for direct glare. Integrated LED option always comes with a diffuser (see previous page).

The Ignis and Imber were inspired by the same design principles that make Cerno and ICRAVE well suited to collaborate. Honesty, simplicity, elemental, timeless and quality are words that sit at the core of both companies' design ethos and we believe these light fixtures embrace these qualities well. Each fixture was reduced to its essential parts – frame and shade – highlighting the interplay of the components, and accentuating the clean lines of the form.

ICRAVE / Cerno

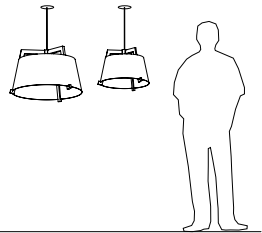



Ico pendant

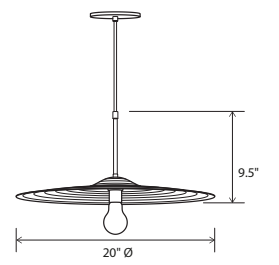

Dimensions: 20" Ø, 9.5"
 Materials: solid brass
 Product weight: 6 lb
 Light source: medium base E26 socket
 Lamping: 1x E26 base, 60 W max
 Bulbs not included
 Input voltage: 250 V AC max
 Textured Black Powdercoat (CM-049)
 low profile round canopy with Black Cloth Covered Cord (CM-090)
 Canopy dimensions: 5" Ø, 0.3"
 See website for more canopy information
 Field adjustable drop length: 0'9" min - 8'0" max
 Suitable for a sloped ceiling
 Specifications subject to change

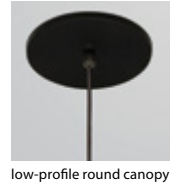
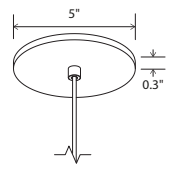

low-profile round canopy



MATERIAL & FINISH OPTIONS

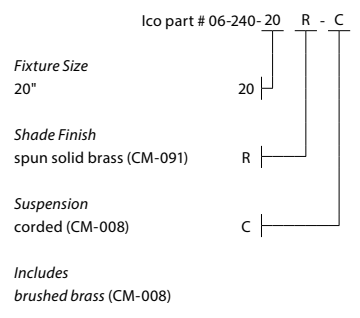

After working with drum cymbals on a few custom projects, we grew to appreciate the design and engineering that goes into these beautiful objects. Cymbals have a simple form, rich texture, and a beautiful brass finish. Modernism is often about utilizing what already exists and repurposing things, which is what we did with this fixture. The Ico looks excellent when paired with a simple light bulb.

Nick Sheridan
 Designer

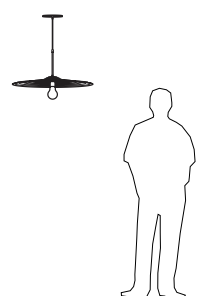

Calx 10
accent pendant

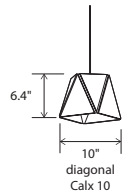

Dimensions: 6.75" x 6.75", 6.4"
Materials: wood, metal, polymer
Product weight: 2 lb
Light source: integrated LED
Light output: 345 Lumens (source)
Light color: 2700 K or 3500 K
Color accuracy: 90+ CRI
Power usage: 3.2 W
Dimmable (see driver below)
Driver location: must be housed in J-box
Driver dimensions: 2" x 1.3" x 1", included
White (CM-060) low-profile round canopy with white braided cord included
Canopy dimensions: 5"Ø, 0.3"
See website for more canopy information
72" drop length, field adjustable
Suitable for a sloped ceiling
Wood grain will vary
Specifications subject to change



MATERIAL & FINISH OPTIONS

Calx 10 part # 06-200-10

Metal Finish
brushed aluminum (CM-012) A
brushed rose gold (CM-046) G
brushed brass (CM-047) R

Wood Finish
walnut (CM-055) W
dark stained walnut (CM-056) D

Lamping
2700 K LED 27
3500 K LED 35

Driver
120VAC input voltage
ELV dimming only P1

Calx sconce also available. Click here.

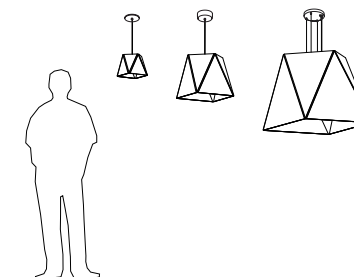

Calx 19
pendant

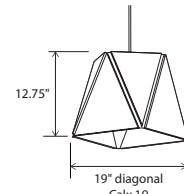

Dimensions: 13" x 13", 12.75"
Materials: wood, metal, polymer
Product weight: 7 lb
Suitable for a sloped ceiling

Integrated LED Specifications
Light output: 1250 Lumens (source)
Light color: 2700 K or 3500 K
Color accuracy: 90+ CRI
Power usage: 13 W
Dimmable (see driver below)

White (CM-060) extended-profile round canopy with white braided cord and steel cable included
Canopy dimensions: 5"Ø, 2"
Canopy required to house LED driver (3.3" x 1.6" x 1.0")
See below for more canopy information
72" drop length, field adjustable

Medium Base Specifications

Lamping: 1x E26 base, type A lamp, 60 W max
Bulb not included
Input voltage: 250 V AC max
White (CM-060) low-profile round canopy with white SPT cord and steel cable included
Canopy dimensions: 5"Ø, 0.3"
72" drop length, field adjustable
Suitable for a sloped ceiling
Wood grain will vary
Specifications subject to change



MATERIAL & FINISH OPTIONS

Calx 19 part # 06-200-19

Metal Finish
brushed aluminum (CM-012) A
brushed rose gold (CM-046) G
brushed brass (CM-047) R

Wood Finish
walnut (CM-055) W
dark stained walnut (CM-056) D

Lamping
2700 K LED 27
3500 K LED 35
medium base E26 socket MB

Driver (LED version only)
120-277 V AC input voltage
0-10 V dimming
TRIAC and ELV dimming at 120 V AC only P1

Includes
frosted polymer diffuser (CM-057)

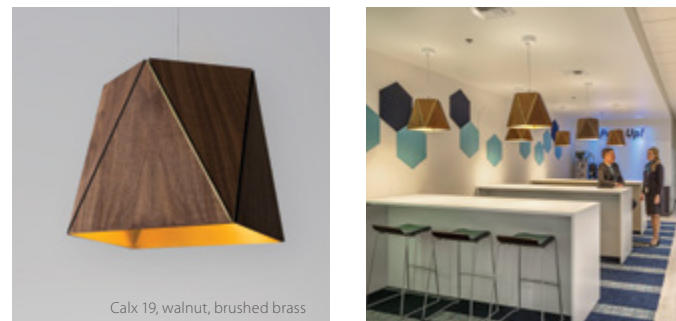

The Calx is an example of modern design where the methods and the materials themselves are integral to its very conception, aligning form and function, which creates a synergy that is evident. The fixture ultimately forms a square aperture but enjoys a beautifully simple faceted structure.

Nick Sheridan,
Designer

Calx 36
pendant

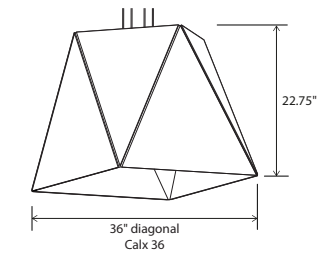

Dimensions: 25" x 25", 22.75"
Materials: wood, metal, polymer
Product weight: 18 lb
Light source: 4x GU-24 base socket
Lamping: 4x GU-24 base, 18 W max each
Bulbs not included
Input voltage: 300 V AC max
White (CM-060) 8" round canopy included
Canopy dimensions: 8"Ø, 1.25"
See page left and website for more canopy information
96" drop length, field adjustable
Suitable for a sloped ceiling
Wood grain will vary
Specifications subject to change



MATERIAL & FINISH OPTIONS

Calx 36 part # 06-200-36

Metal Finish
brushed aluminum (CM-012) A
brushed rose gold (CM-046) G
brushed brass (CM-047) R

Wood Finish
walnut (CM-055) W
dark stained walnut (CM-056) D

Includes
frosted polymer diffuser (CM-057)

Calx sconce also available. Click here.

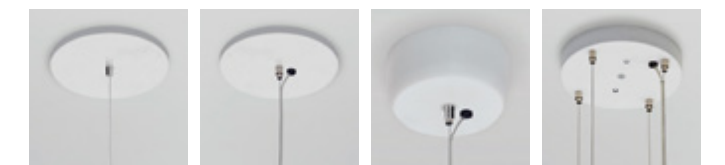
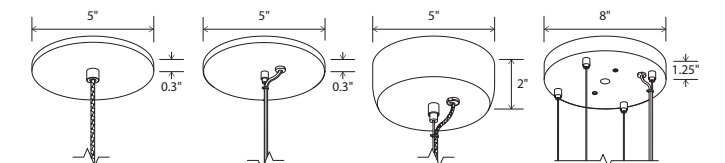

Calx 10 low-profile round canopy with braided cord
Calx 19 E26 low-profile round canopy with white SPT with steel cable
Calx 19 Integrated LED extended-profile round canopy with steel cable
Calx 36 8" round canopy clear SPT with four 1/16" Ø steel cables

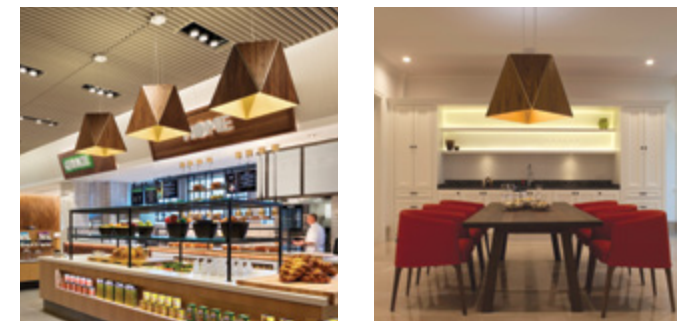

Abeo
pendant

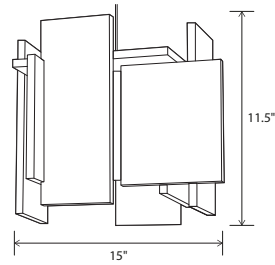

Dimensions: 15" Ø, 11.5"
 Materials: solid wood, polymer
 Product weight: 7 lb
 Light source: integrated LED
 Light output: 1250 Lumens (source)
 Light color: 2700 K or 3500 K
 Color accuracy: 90+ CRI
 Power usage: 13 W
 Dimmable (see driver below)
 White (CM-060) extended-profile round canopy with white braided cord and steel cable included
 Canopy dimensions: 5.5"Ø, 2"
 Canopy required to house LED driver (3.3" x 1.6" x 1.0")
 See website for more canopy information
 72" drop length, field adjustable
 Suitable for a sloped ceiling
 Wood grain will vary
 Specifications subject to change

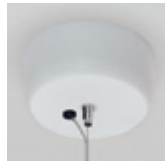
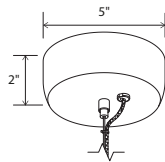

Extended-profile round canopy



walnut (CM-001)



dark stained walnut (CM-002)

MATERIAL & FINISH OPTIONS

Abeo part # 06-190-

Wood Body
 walnut (CM-001)
 dark stained walnut (CM-002)

Lamping
 2700 K LED
 3500 K LED

Driver
 120-277 V AC input voltage
 0-10 V dimming
 TRIAC and ELV dimming at 120 V AC only

Includes
 frosted polymer (CM-024)

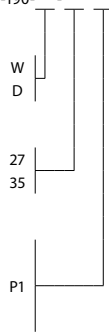

Abeo, walnut

I wanted to create a simple geometric sculpture that lets the light inside just sneak out around the floating walnut planes: letting the natural wood fall in and out of the light. It is this play with contrast and light and shadow that makes the Abeo such a dynamic piece.

Nick Sheridan
 Designer



Clauo, walnut

The Clauo showcases the beautiful natural walnut wood grain and sets it against the rigorous slits cut in each face as they wrap around the simple, clean shade form. A beautiful glow emanates from each slit, showing the striking rectilinear composition, in which all four sides are unique.

Nick Sheridan
 Designer

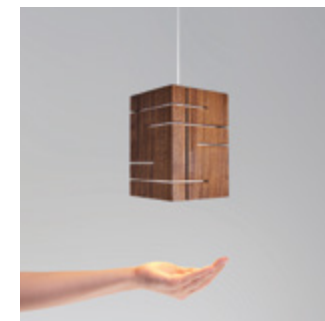

Clauo
accent pendant

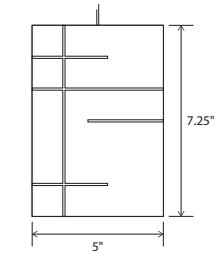

Dimensions: 5" x 5", 7.25"
 Materials: solid wood, polymer
 Product weight: 3 lb
 Light source: integrated LED
 Light output: 345 Lumens (source)
 Light color: 2700 K or 3500 K
 Color accuracy: 90+ CRI
 Power usage: 3.2 W
 Dimmable (see driver below)
 Driver location: must be housed in J-box
 Driver dimensions: 2" x 1.3" x 1", included
 Brushed aluminum (CM-006) low-profile square canopy with white braided cord included
 Canopy dimensions: 4.5" x 4.5", 0.38"
 Must use included external LED driver (2.25" x 1.5" x 1")
 Accent pendants can be clustered by using multi-point round canopy or multi-point linear canopy
 See website for more canopy information
 72" drop length, field adjustable
 Suitable for a sloped ceiling
 Wood grain will vary
 Specifications subject to change

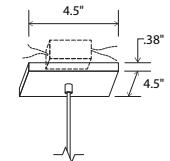

low-profile square canopy



walnut (CM-001)



dark stained walnut (CM-002)

MATERIAL & FINISH OPTIONS

Clauo part # 06-110-

Wood Body
 walnut (CM-050)
 dark stained walnut (CM-002)

Lamping
 2700 K LED
 3500 K LED

Driver
 120 V AC input voltage
 ELV dimming only

Includes
 frosted polymer (CM-024)

Also available in a sconce version

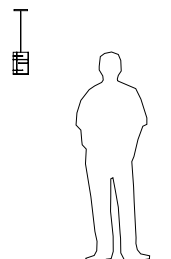
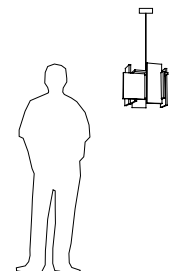
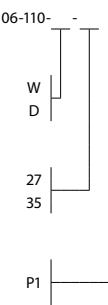



Mica L
pendant

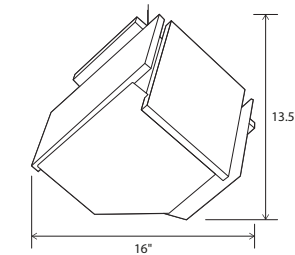

Dimensions: 16" Ø, 13.5"
Materials: solid wood, polymer
Product weight: 8 lb
Suitable for a sloped ceiling

Integrated LED Specifications

Light output: 1250 Lumens (source)
Light color: 2700 K or 3500 K
Color accuracy: 90+ CRI
Power usage: 13 W
Dimmable (see driver below)
Brushed aluminum (CM-006) extended-profile square canopy with white braided cord included
Canopy dimensions: 4.5" x 4.5", 1.63"
Canopy required to house LED driver (3.3" x 1.6" x 1.0")
See website for more canopy information
6'-0" drop length, field adjustable

Medium Base Specifications

Lamping: E26 base, type A lamp, 60 W max
Bulb not included
Input voltage: 250 V AC max
White (CM-060) low-profile round canopy with clear SVT cord included
Canopy dimensions: 5"Ø, 0.3"
6'-0" drop length, field adjustable

Wood grain will vary
Specifications subject to change



MATERIAL & FINISH OPTIONS

Mica L part # 06-180-

Wood Body
walnut (CM-001)
dark stained walnut (CM-002)

Lamping
2700 K LED
3500 K LED
medium base E26 socket

Driver (LED version only)
120-277 V AC input voltage
0-10 V dimming
TRIAC and ELV dimming at 120 V AC only

Includes
frosted polymer (CM-024)

Mica
accent pendant

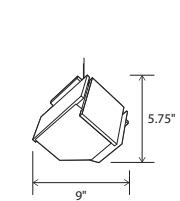

Dimensions: 9" Ø, 5.75"
Materials: solid wood, polymer
Product weight: 3 lb
Light source: integrated LED
Light output: 345 Lumens (source)
Light color: 2700 K or 3500 K
Color accuracy: 90+ CRI
Power usage: 3.2 W
Dimmable (see driver below)
Driver location: must be housed in J-box
Driver dimensions: 2" x 1.3" x 1", included
Brushed aluminum (CM-006) low-profile square canopy with white braided cord included
Canopy dimensions: 4.5" x 4.5", 0.38"
External LED driver (2.25" x 1.5" x 1")
Accent pendants can be clustered by using multi-point round canopy or multi-point linear canopy
See website for more canopy information
6'-0" drop length, field adjustable
Suitable for a sloped ceiling
Wood grain will vary
Specifications subject to change

Integrated LED Specifications

Light output: 345 Lumens (source)
Light color: 2700 K or 3500 K
Color accuracy: 90+ CRI
Power usage: 3.2 W
Dimmable (see driver below)
Driver location: must be housed in J-box
Driver dimensions: 2" x 1.3" x 1", included
Brushed aluminum (CM-006) low-profile square canopy with white braided cord included
Canopy dimensions: 4.5" x 4.5", 0.38"
External LED driver (2.25" x 1.5" x 1")
Accent pendants can be clustered by using multi-point round canopy or multi-point linear canopy
See website for more canopy information
6'-0" drop length, field adjustable
Suitable for a sloped ceiling
Wood grain will vary
Specifications subject to change

Medium Base Specifications

Lamping: E26 base, type A lamp, 60 W max
Bulb not included
Input voltage: 250 V AC max
White (CM-060) low-profile round canopy with clear SVT cord included
Canopy dimensions: 5"Ø, 0.3"
6'-0" drop length, field adjustable

Wood grain will vary
Specifications subject to change



MATERIAL & FINISH OPTIONS

Mica part # 06-160-

Wood Body
walnut (CM-001)
dark stained walnut (CM-002)

Lamping
2700 K LED
3500 K LED

Driver
120 V AC input voltage
ELV dimming only

Includes
frosted polymer (CM-024)

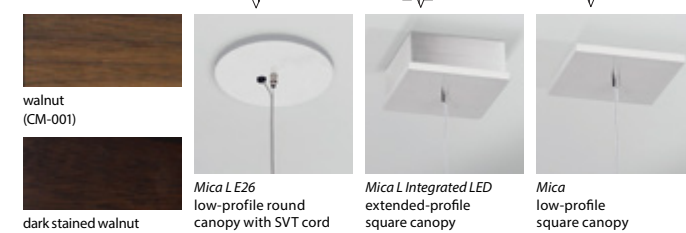
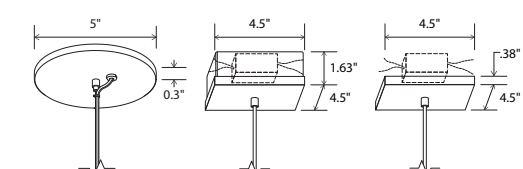

The Mica is simply a cube, which has been carefully deconstructed to a sculptural state. By way of the fixture's orientation and petal material composition, it exudes a certain organic symmetry. The Mica accent pendant acts as a beautiful node, creating a sense of space marked with an ambient glow.

Nick Sheridan
Designer

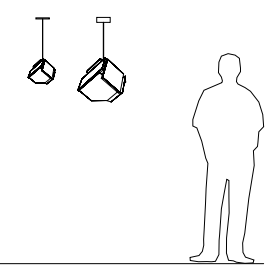

Levis
accent pendant

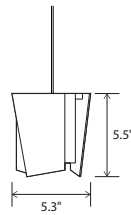

Dimensions: 5.3" Ø, 5.5" H
 Materials: polymer, veneer and aluminum options
 Product weight: 1 lb
 Energy efficient LED light source
 Light output: 345 Lumens (source)
 Light color: 2700 K (warm) or 3500 K (cool)
 Color accuracy: 90+ CRI
 LED power consumption: 3.2W
 Dimmable (see driver below)
 Driver location: must be housed in J-box
 Driver dimensions: 2" x 1.3" x 1", included
 Brushed aluminum (CM-006) Low-Profile Square Canopy included
 Canopy dimensions: 4.5" x 4.5", 0.38"
 Must use included external LED driver (2.25" x 1.5" x 1")
 Accent pendants can be clustered by using Multi-Point Round Canopy or Multi-Point Linear Canopy
 See website for more canopy information
 6'-0" drop length, field adjustable
 Suitable for a sloped ceiling
 Wood grain will vary
 Specifications subject to change



Levis L
pendant

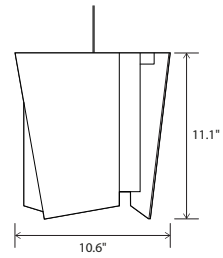

Dimensions: 10.6" Ø, 11.1"
 Materials: polymer, veneer and aluminum options
 Product weight: 7 lb
 Suitable for a sloped ceiling
Integrated LED Specifications
 Light output: 1250 Lumens (source)
 Light color: 2700 K or 3500 K
 Color accuracy: 90+ CRI
 Power usage: 13 W
 Dimmable (see driver below)
 Brushed aluminum (CM-006) extended-profile square canopy with white braided cord included
 Canopy dimensions: 4.5" x 4.5", 1.63"
 Canopy required to house LED driver (3.3" x 1.6" x 1.0")
 See website for more canopy information
 6'-0" drop length, field adjustable
Medium Base Specifications
 Lamping: E26 base, type A lamp, 60 W max
 Input voltage: 250 V AC Max
 White (CM-060) low-profile round canopy with clear SVT cord included
 Canopy dimensions: 5"Ø, 0.3"
 6'-0" drop length, field adjustable
 Specifications subject to change



MATERIAL & FINISH OPTIONS

Levis accent part # 06-100-

Shade	
frosted polymer (CM-024)	F
beech wood veneer (CM-019)	B
brushed aluminum (CM-012)	A
Lamping	
2700 K LED	27
3500 K LED	35
Driver	
120 V AC input voltage	P1
ELV dimming only	

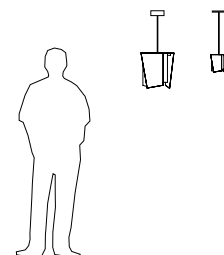

MATERIAL & FINISH OPTIONS

Levis L part # 06-170-

Shade	
frosted polymer (CM-024)	F
beech wood veneer (CM-019)	B
brushed aluminum (CM-012)	A
Lamping	
2700 K LED	27
3500 K LED	35
medium base E26 socket	MB
Driver (LED version only)	
120-277 V AC input voltage	P1
0-10 V dimming	
TRIAC and ELV dimming at 120 V AC only	

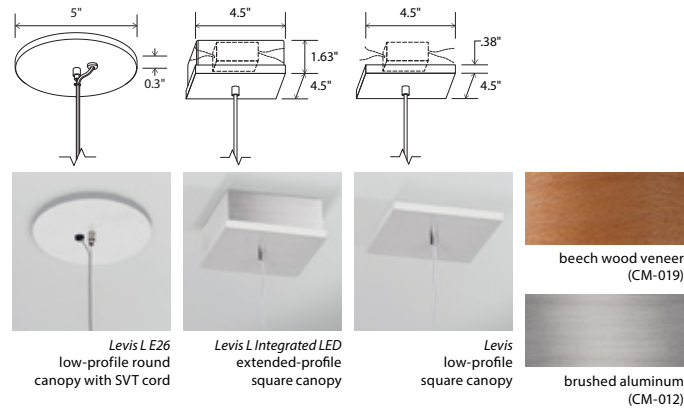

The Levis is simple and clean at first glance: complex upon closer review. The rhythm in the facets gives a dynamic feel from different vantage points, creating a sophistication to its presence.

Nick Sheridan
Designer



Levis L, frosted polymer

Salix
accent pendant

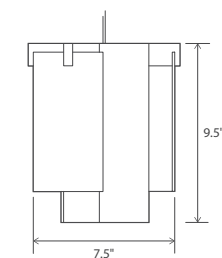

Dimensions: 7.5" x 7.5", 9.0"
 Materials: solid wood, polymer, aluminum
 Product weight: 3 lb
 Light source: integrated LED
 Light output: 345 Lumens (source)
 Light color: 2700 K or 3500 K
 Color accuracy: 90+ CRI
 Power usage: 3.2 W
 Dimmable (see driver below)
 Driver location: must be housed in J-box
 Driver dimensions: 2" x 1.3" x 1", included
 Brushed aluminum (CM-006) low-profile square canopy with white braided cord included
 Canopy dimensions: 4.5" x 4.5", 0.38"
 Must use included external LED driver (2.25" x 1.5" x 1")
 Accent pendants can be clustered by using multi-point round canopy or multi-point linear canopy
 See website for more canopy information
 6'-0" drop length, field adjustable
 Suitable for a sloped ceiling
 Wood grain will vary
 Specifications subject to change

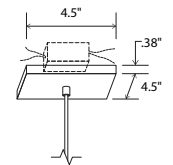

low-profile square canopy

MATERIAL & FINISH OPTIONS

Salix part # 06-120-W A -

Wood Body	
walnut (CM-001)	W
Metal Finish	
brushed aluminum (CM-012)	A
Lamping	
2700 K LED	27
3500 K LED	35
Driver	
120VAC input voltage	P1
ELV dimming only	

Includes
frosted polymer (CM-024)



Salix, brushed aluminum



The Salix pendant's materials and proportions are in perfect harmony. The brushed aluminum set against the oiled walnut in this fixture still feels strikingly fresh and beautiful after years of production.

Nick Sheridan
Designer

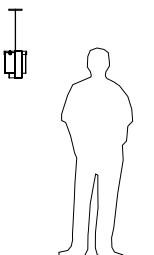



The Plura is a simple, straight forward fixture that is excellently executed. With the Plura it was about resolving the seams and edges and their relationships to one another. The result is a scalable fixture that has a sharp, sophisticated feel.

Nick Sheridan
Designer







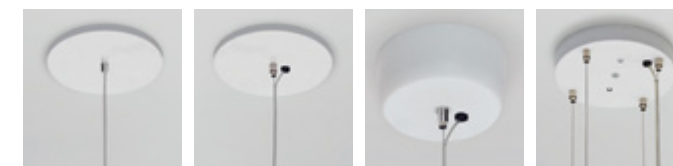
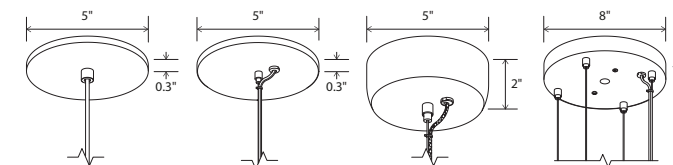

BOBBY BERK INTERIORS AND DESIGN

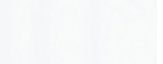

Plura 36 Pendant, walnut

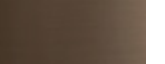

Plura 18 and Plura 24 low-profile round canopy with white SVT
 Plura 30 GU-24 Base Sockets low-profile round canopy clear SPT with steel cable
 Plura 30 Integrated LED extended round canopy, clear SPT with steel cable
 Plura 36 8" round canopy clear SPT with four 1/16" Ø steel cables

 white washed oak (CM-095)	 frosted polymer (CM-051)	 brushed rose gold (CM-046)	
 walnut (CM-001)	 matte black (CM-085) with matte white interior	 brushed brass (CM-047)	 gloss white (CM-054)
 dark stained walnut (CM-002)	 brushed aluminum (CM-012)	 distressed brass (CM-096)	

Plura pendant

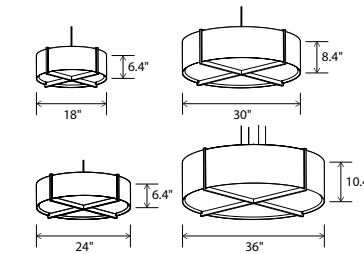

Dimensions:
 Plura 18: 18" Ø, 6.4"
 Plura 24: 24" Ø, 6.4"
 Plura 30: 30" Ø, 8.4"
 Plura 36: 36" Ø, 10.4"
 Materials: solid wood, polymer
 Product weight:
 Plura 18: 5 lb
 Plura 24: 6 lb
 Plura 30: 9 lb
 Plura 36: 13 lb

Integrated LED Specifications
 Light output:
 Plura 18 & 24: 1690 Lumens (source)
 Plura 30 & 36: 2815 Lumens (source)
 Light color: 2700 K or 3500 K
 Color accuracy: 90+ CRI
 Power usage:
 Plura 18 & 24: 19.5 W
 Plura 30 & 36: 32.5 W
 Dimmable (see driver below)
 Plura 18 & 24 driver location: must be housed in J-box
 Driver dimensions: 3.3" x 1.6" x 1", included
 Plura 30 & 36 driver location: housed in canopy

GU-24 Base Specifications
 Light source:
 Plura 18 & 24: 2x GU-24 base socket
 Plura 30 & 36: 4x GU-24 base socket
 Lamping:
 Plura 18 & 24: 2x GU-24 base, 18 W max each
 Plura 30 & 36: 4x GU-24 base, 18 W max each
 Bulbs not included
 Input voltage: 300 V AC max

96" drop length, field adjustable
 Suitable for a sloped ceiling
 Wood grain will vary
 Specifications subject to change



MATERIAL & FINISH OPTIONS

Plura pendant part # 06-230-

Ø:	
18" Ø	18
24" Ø	24
30" Ø	30
36" Ø	36

Wood Body	
walnut (CM-001)	W
dark stained walnut (CM-002)	D
white washed oak (CM-095)	O

Shade Material	
frosted polymer (CM-051)	F
matte black (CM-085)	B
with matte white interior	
brushed aluminum (CM-012)	A
brushed rose gold (CM-046)	R
brushed brass (CM-047)	G
distressed brass (CM-096)	D
gloss white (CM-054)	W

Lamping	
2700 K LED	27
3500 K LED	35
GU-24 base sockets	GU

Driver (LED version only)	
120-277 V AC input voltage	
0-10 V dimming	
TRIAC and ELV dimming at 120 V AC only	P1

Includes
 frosted polymer (CM-051)

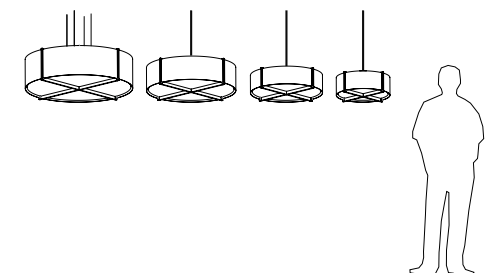



Plura 36 flush mount, walnut

Plura
flush mount

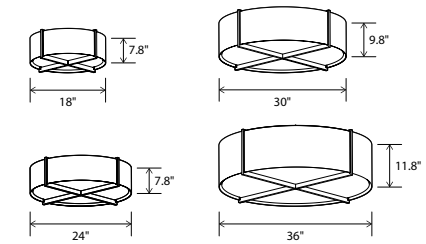

Dimensions:
 Plura 18: 18" Ø, 7.8"
 Plura 24: 24" Ø, 7.8"
 Plura 30: 30" Ø, 9.8"
 Plura 36: 36" Ø, 11.8"
Materials: solid wood, metal, polymer
Product weight:
 Plura 18: 5 lb
 Plura 24: 6 lb
 Plura 30: 9 lb
 Plura 36: 13 lb

Integrated LED Specifications
Light output:
 Plura 18 & 24: 1690 Lumens (source)
 Plura 30 & 36: 2815 Lumens (source)
Light color: 2700 K or 3500 K
Color accuracy: 90+ CRI
Power usage:
 Plura 18 & 24: 19.5 W
 Plura 30 & 36: 32.5 W
 Dimmable (see driver below)

GU-24 Base Specifications
Light source:
 Plura 18 & 24: 2x GU-24 base socket
 Plura 30 & 36: 4x GU-24 base socket
Lamping:
 Plura 18 & 24: 2x GU-24 base, 18 W max each
 Plura 30 & 36: 4x GU-24 base, 18 W max each
Bulbs not included
Input voltage: 300 V AC max

Suitable for a sloped ceiling
 Wood grain will vary
 Specifications subject to change



Emergency backup option available upon request
 Also available in a pendant version

MATERIAL & FINISH OPTIONS

Plura flush mount part # 08-100-

Ø:		
18" Ø	18	
24" Ø	24	
30" Ø	30	
36" Ø	36	

Wood Body		
walnut (CM-001)	W	
dark stained walnut (CM-002)	D	
white washed oak (CM-095)	O	

Shade Material		
frosted polymer (CM-051)	F	
matte black (CM-085)	B	
with matte white interior		
brushed aluminum (CM-012)	A	
brushed rose gold (CM-046)	R	
brushed brass (CM-047)	G	
distressed brass (CM-096)	D	
gloss white (CM-054)	W	

Lamping		
2700 K LED	27	
3500 K LED	35	
GU-24 base sockets	GU	

Driver (LED version only)		
120-277 V AC input voltage		
0-10 V dimming		
TRIAC and ELV dimming at 120 V AC only	P1	

Includes
 frosted polymer (CM-051)

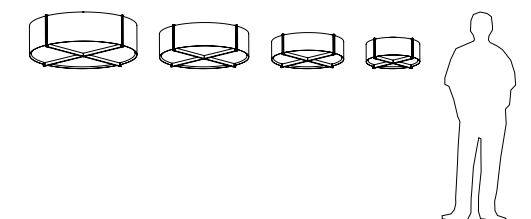

Sconces

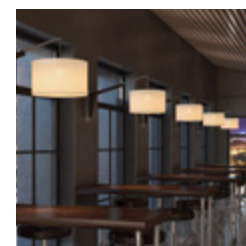

Talea

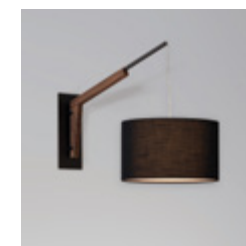

Talea

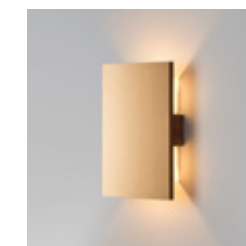

Tersus



Sedo



Via

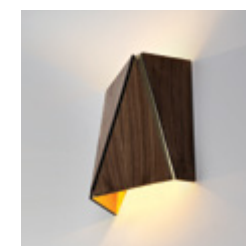

Calx Sconce



Ansa

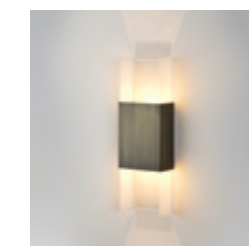

Ansa

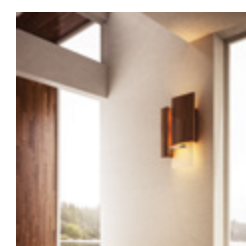

Vesper

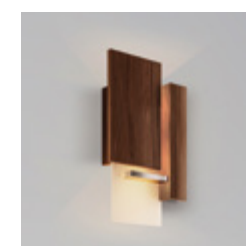

Vesper



Fortis

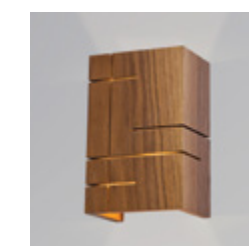

Claudo Sconce

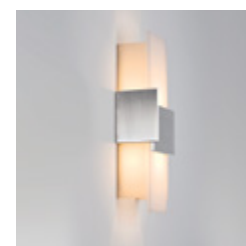

Acuo

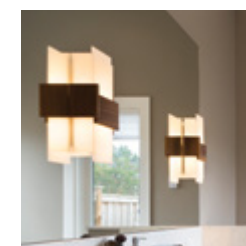

Acuo



Cubo



Libri

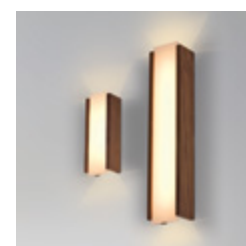

Capiro family

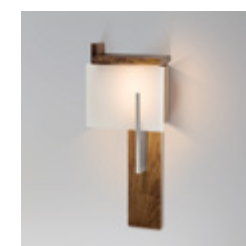

Oris

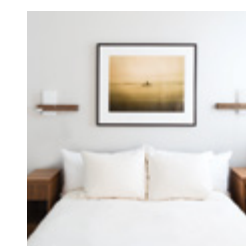

Levo



Levo



Talea, burlap shade, walnut body, textured black powdercoat

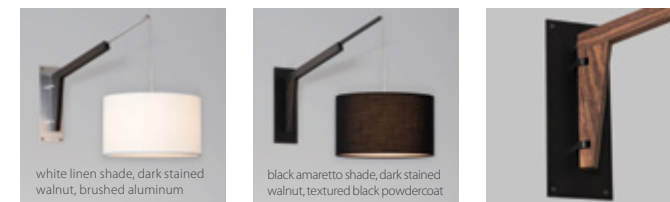

white linen shade, dark stained walnut, brushed aluminum

black amaretto shade, dark stained walnut, textured black powdercoat

The adaptive and interactive features of the Talea introduced exciting challenges to the design process. I believe we found a balance that allows this fixture to thrive in a range of spaces and different applications. I am really pleased with how the design language turned out, specifically how the expressive hinge suggests its ability to swing, and how the wood to metal arm detailing suggests the arm can telescope. It's a beautiful mixture of utility and elegance.

Nick Sheridan
Designer

Talea, white linen shade, dark stained walnut body, brushed aluminum,

Talea
articulate wall sconce

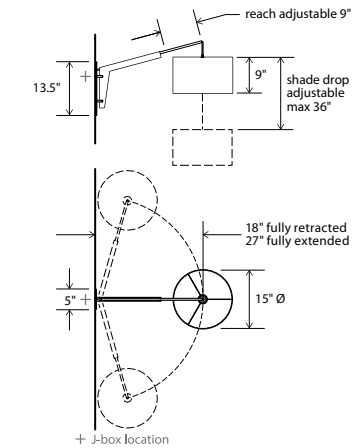

Dimensions: 18.38" x 5" x 34.75", 15" Ø shade
Materials: solid wood, metal
Product weight: 5 lb
Light source: medium base E26 socket
Lamping: E26 base, type A lamp, 60 W max
Bulb not included
Input voltage: 250 V AC max
Clear SVT-3 cord included
Top and bottom diffusers included (CM-051)
Wood grain will vary
Specifications subject to change
Patent No.: US D846,180 S



SWING ARM LENGTH
Arm length (from the wall to center of shade) can be adjusted between 18" and 27"

DROP LENGTH
Max drop length from tip of extended arm to top of shade is 36"

SWING ARM ROTATION
Adjustable resistance in pivot hinge

MATERIAL & FINISH OPTIONS

Talea part # 03-210-

Metal Finish
brushed aluminum (CM-006) A
textured black powdercoat (CM-049) B

Wood Body
walnut (CM-001) W
dark stained walnut (CM-002) D

Fabric Shade
burlap (CM-017) N
white linen (CM-016) L
black amaretto (CM-018) A

Includes
frosted polymer diffuser (CM-051)

For additional products that utilize the swing arm bracket, please see our Motus Swing Arm Bracket on page 78



brushed aluminum (CM-006)



textured black (CM-049)



walnut (CM-001)



dark stained walnut (CM-002)



burlap (CM-017)

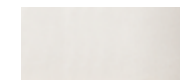

white linen (CM-016)



black amaretto (CM-018)

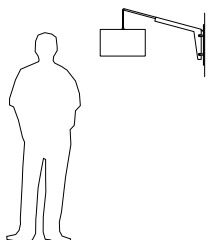

Via
sconce or ceiling flush mount

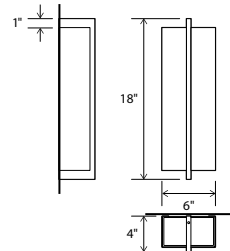

Dimensions: 18" x 6" x 4"
Materials: solid wood, polymer
Product weight: 2 lb

Integral LED Specifications
Light output: 500 Lumens (source)
Light color: 2700 K or 3500 K
Color accuracy: 90+ CRI
Power usage: 7 W
Dimmable (see driver below)
Input voltage: 24 V DC (driver included)
Driver location: must be housed in J-box
Driver dimensions: 3" x 1.5" x 1"
Mounting: ceiling or wall

Candelabra Base Specifications
Lamping: 2x candelabra E12 base sockets,
10 W max each (bulbs not included)
Select bulbs can achieve over 500 lumens each
Input voltage: 120 V AC max
Mounting: wall only



MATERIAL & FINISH OPTIONS

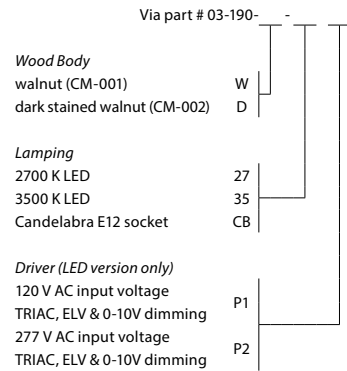

Includes
frosted polymer (CM-051)

Inquire about other input voltages
Emergency backup option available upon request

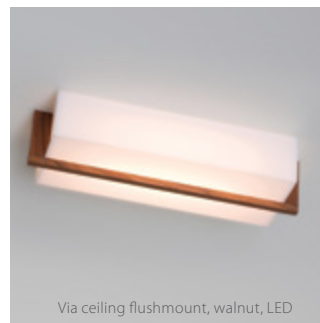
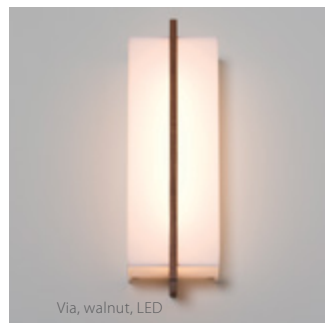

The Via has an understated geometry with sophisticated detailing and proportion. The substantial glowing volume of the Via is punctuated by a thin plane of rich American walnut striking a balance and harmony.

Nick Sheridan
Designer

Calx
sconce

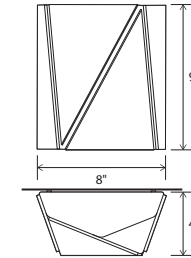

Dimensions: 8" x 9" x 4"
Materials: wood, metal
Product weight: 2 lb
Light source: integrated LED
Light output: 1130 Lumens (source)
Light color: 2700 K or 3500 K
Color accuracy: 90+ CRI
Power usage: 13 W
Dimmable (see driver below)
Wood grain will vary
Specifications subject to change



MATERIAL & FINISH OPTIONS

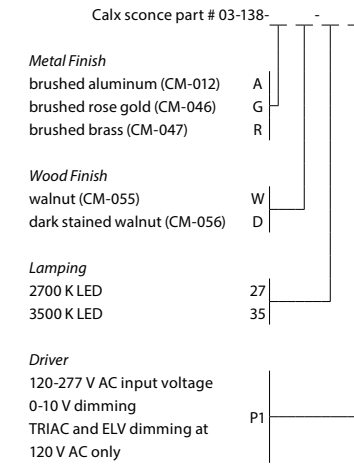

Calx pendants also available. [Click here.](#)

Inspired by the Calx pendant, the materials and method inform the design greatly. While the Calx sconce is clean and simple, it also offers a beautiful texture and subtle complexity to a wall.

Nick Sheridan
Designer

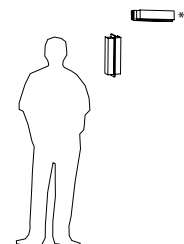
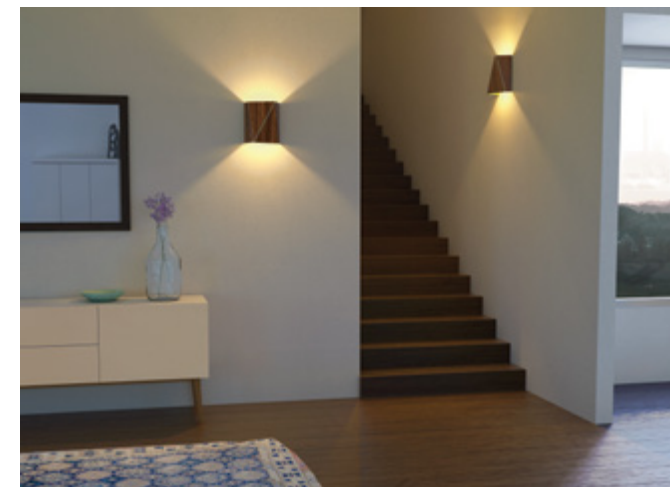

* LED version only

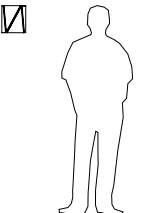

Penna 16 / Penna 40 / Penna 64
sconce

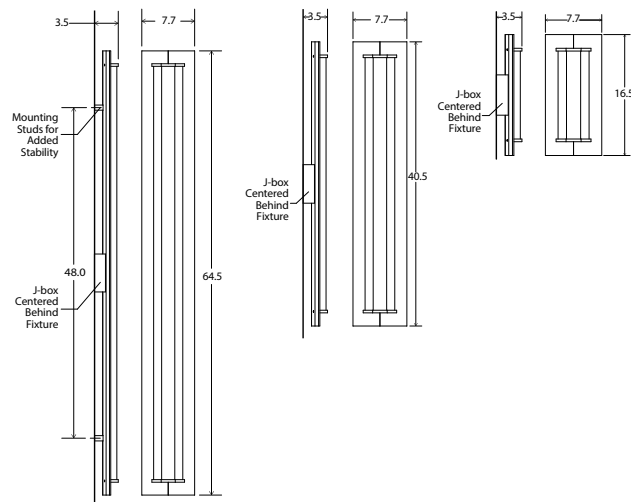

Penna 16 dimensions: 16.5" x 7.7" x 3.5"
 Penna 40 dimensions: 40.5" x 7.7" x 3.5"
 Penna 64 dimensions: 64.5" x 7.7" x 3.5"
 Penna 16 weight: 4 lb
 Penna 40 weight: 6 lb
 Penna 64 weight: 9 lb
 Light source: integrated LED
 Penna 16 light output: 510 Lumens (source)
 Penna 40 light output: 1530 Lumens (source)
 Penna 64 light output: 2550 Lumens (source)
 Light color: 2700 K or 3500 K
 Color accuracy: 90+ CRI
 Penna 16 power usage: 7 W
 Penna 40 power usage: 21 W
 Penna 64 power usage: 35 W
 Dimmable (see driver below)
 Wood grain will vary
 Specifications subject to change

MATERIAL & FINISH OPTIONS

Penna sconce part # 03-220-	
Penna 16	16
Penna 40	40
Penna 64	64
Metal Finish	
brushed brass (CM-008)	R
distressed brass (CM-009)	D
Wood Body	
walnut (CM-001)	W
dark stained walnut (CM-002)	D
Lamping	
2700 K LED	27
3500 K LED	35
Driver	
120 V AC input voltage	P1
TRIAC, ELV & 0-10 V dimming	
277 V AC input voltage	P2
TRIAC, ELV & 0-10 V dimming	
Includes frosted polymer (CM-057)	



Penna 16 walnut / Penna 40 dark stained walnut 40 / Penna 64 walnut

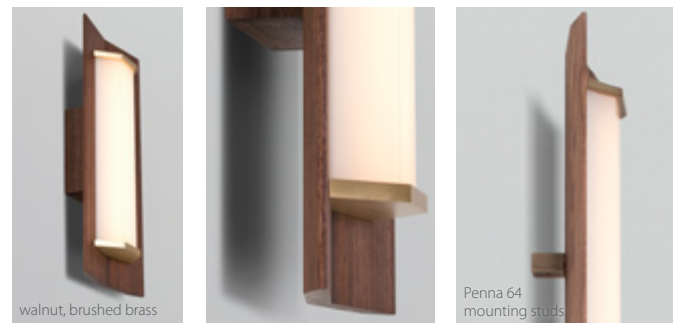

On our Cerno journey, we continue to evolve as designers and craftsman. The Penna is a celebration of us drawing and reflecting on our last ten years. This design is an embodiment of all the lessons that we have learned from designing and building thousands of lights. This fixture balances utility and sophisticated beauty well. The walnut, brass, and leather work in concert to compose a modern form with materials that have been used for thousands of years.

Nick Sheridan
Designer



Vesper, walnut

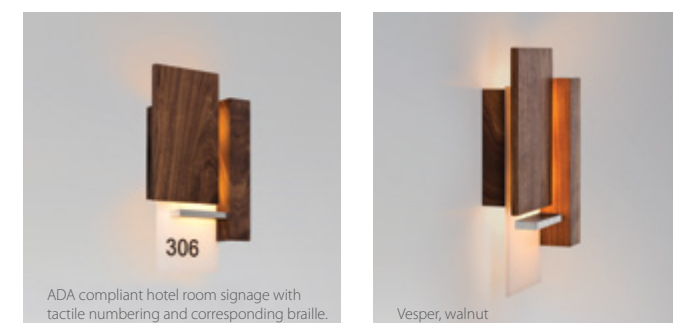

ADA compliant hotel room signage with tactile numbering and corresponding braille.

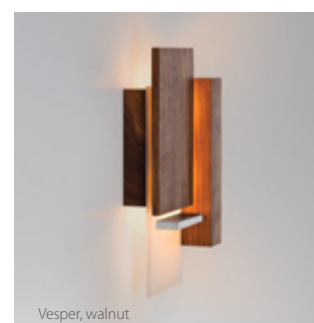

Vesper, walnut

The Vesper is a very simple geometric sculpture composed of brushed aluminum, American black walnut, and white polymer. The light not only washes up and down the wall but also filters out through the composition, exhibiting the fixture's depth in three dimensions.

Nick Sheridan
Designer

Vesper
sconce

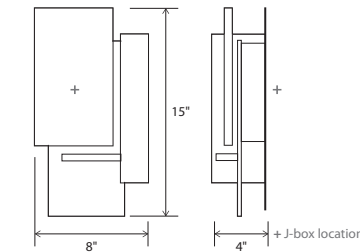

Dimensions: 15" x 8" x 4"
 Materials: solid wood, polymer, aluminum
 Product weight: 4 lbs
 Light source: integrated LED
 Light output: 1130 Lumens (source)
 Light color: 2700 K or 3500 K
 Color accuracy: 90+ CRI
 LED power consumption: 13W
 Dimmable (see driver below)
 ADA compliant hotel room signage with tactile numbering and corresponding braille available
 Wood grain will vary
 Specifications subject to change



MATERIAL & FINISH OPTIONS

Vesper part # 03-132-	
Wood Body	
walnut (CM-001)	W
dark stained walnut (CM-002)	D
Lamping	
2700 K LED	27
3500 K LED	35
Driver	
120-277 V AC input voltage	P1
0-10V dimming	
TRIAC and ELV dimming at 120 V AC only	
Includes frosted polymer (CM-024) brushed aluminum (CM-006)	



Acuo
sconce

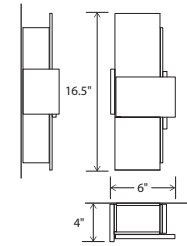

Dimensions: 16.5" x 6" x 4"
 Materials: solid wood, polymer, aluminum
 Product weight:
 3 lb (CM-001/CM-002)
 5 lb (CM-006)
Integrated LED Specifications
 Light output: 1130 Lumens (source)
 Light color: 2700 K or 3500 K
 Color accuracy: 90+ CRI
 Power usage: 13 W
 Dimmable (see driver below)

GU-24 Base Specifications
 Lamping: 2x GU-24 base sockets, 18 W max each
 Input voltage: 300 V AC max

ADA compliant hotel room signage with tactile numbering and corresponding braille available

Wood grain will vary
 Specifications subject to change



MATERIAL & FINISH OPTIONS

Acuo part # 03-130-

Body	
walnut (CM-001)	W
dark stained walnut (CM-002)	D
brushed aluminum (CM-006)	A
Lamping	
2700 K LED	27
3500 K LED	35
GU-24 base sockets	GU
Driver (LED version only)	
120-277 V AC input voltage	
0-10 V dimming	
TRIAC and ELV dimming at 120 V AC only	P1

Includes
 frosted polymer (CM-024)

J-box centered behind wood/aluminum body



Acuo, walnut



Acuo, walnut



Acuo, brushed aluminum

It's a 3 sided box, which has been carefully deconstructed to a sculptural state. The careful composition of overlap and void create interest and complexity to a very straightforward, well-functioning wall sconce. The tectonic disconnection in form allows you to witness the solid American black walnut's grain as it travels through each solid block.

Nick Sheridan
 Designer

Emergency backup option available upon request, requires oversized J-box.



Acuo, walnut

SARAH GALLOP INTERIOR DESIGN PHOTO BY PAUL GRDINA

Capio S
sconce

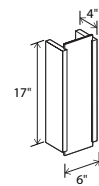

Dimensions: 17" x 6" x 4"
 Materials: solid wood, polymer
 Product weight: 4 lb
 Light source: integrated LED
 Light output: 500 Lumens (source)
 Light color: 2700 K or 3500 K
 Color accuracy: 90+ CRI
 Power usage: 7 W
 Dimmable (see driver below)
 Input voltage: 24 V DC (driver included)
 Driver location: must be housed in J-box
 Driver dimensions: 2.6" x 1.3" x 0.8" ADA compliant hotel room signage with tactile numbering and corresponding braille available
 Wood grain will vary
 Specifications subject to change



Capio L
sconce

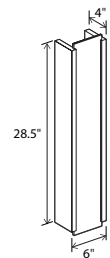

Dimensions: 28.5" x 6" x 4"
 Materials: solid wood, polymer
 Product weight: 7 lb
 Light source: integrated LED
 Light output: 1000 Lumens (source)
 Light color: 2700 K or 3500 K
 Color accuracy: 90+ CRI
 Power usage: 14 W
 Dimmable (see driver below)
 Input voltage: 24 V DC (driver included)
 Driver location: must be housed in J-box
 Driver dimensions: 3" x 1.5" x 1" ADA compliant hotel room signage with tactile numbering and corresponding braille available
 Wood grain will vary
 Specifications subject to change



MATERIAL & FINISH OPTIONS

Capio S part # 03-180-S

Wood Body	W	
walnut (CM-001)	D	
dark stained walnut (CM-002)	M	
Lamping		
2700 K LED	27	
3500 K LED	35	
Driver		
120 V AC input voltage	P1	
TRIAC, ELV & 0-10 V dimming	P2	
277 V AC input voltage		
TRIAC, ELV & 0-10 V dimming		
Includes		
frosted polymer (CM-024)		

MATERIAL & FINISH OPTIONS

Capio L part # 03-180-L

Wood Body	W	
walnut (CM-001)	D	
dark stained walnut (CM-002)	M	
Lamping		
2700 K LED	27	
3500 K LED	35	
Driver		
120 V AC input voltage	P1	
TRIAC, ELV & 0-10 V dimming	P2	
277 V AC input voltage		
TRIAC, ELV & 0-10 V dimming		
Includes		
frosted polymer (CM-024)		



Capio S, Capio L, walnut



dark stained walnut (CM-002)



walnut (CM-001)



maple (CM-005)



Capio L, maple Capio L, walnut

The Capio is an exercise in restraint and efficiency consisting of just two solid wood sides that capture a single light diffusing lens. The clean and simple design allows for horizontal or vertical mounting as well as compelling compositions when used in multiples.

Nick Sheridan
Designer

Emergency backup option available upon request, requires oversized J-box.



Oris, walnut

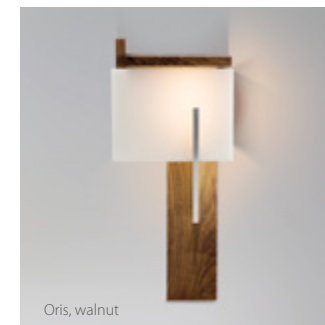

Oris, walnut

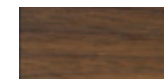

walnut (CM-001)



dark stained walnut (CM-002)

The Oris has a strong and commanding presence with its highly architectonic form. The thick solid stock walnut and solid aluminum central fin give the Oris a feeling of permanence and integration into the surrounding architecture. The simple asymmetrical composition adds an understated complexity, as well as excellent illumination, to any wall.

Nick Sheridan
Designer

Emergency backup option available upon request, requires oversized J-box.

Oris
sconce

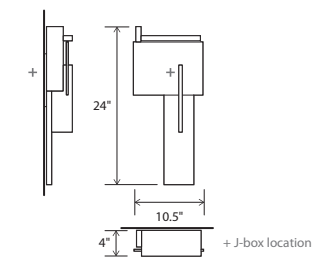

Dimensions: 24" x 10.5" x 4"
 Materials: solid wood, polymer, aluminum
 Product weight: 6 lbs
 Light source: integrated LED
 Light output: 1130 Lumens (source)
 Light color: 2700 K or 3500 K
 Color accuracy: 90+ CRI
 LED power consumption: 13W
 Dimmable (see driver below)
 ADA compliant hotel room signage with tactile numbering and corresponding braille available
 Wood grain will vary
 Specifications subject to change



MATERIAL & FINISH OPTIONS

Oris part # 03-140-

Metal Finish		
brushed aluminum (CM-006)	A	
Wood Body		
walnut (CM-001)	W	
dark stained walnut (CM-002)	D	
Lamping		
2700 K LED	27	
3500 K LED	35	
Driver		
120-277 V AC input voltage	P1	
0-10V dimming	P1	
TRIAC and ELV dimming at 120 V AC only		
Includes		
frosted polymer (CM-024)		

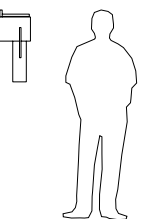
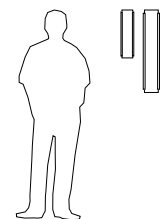



Tersus
sconce

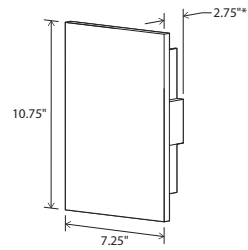

Dimensions: 10.75" x 7.25" x 2.75" (*3.13" marble)
 Materials: solid wood, polymer, metal option, stone option
 Product weight: 2 lb (5 lb marble)
 Light source: integrated LED
 Light output: 1130 Lumens (source)
 Light color: 2700 K or 3500 K
 Color accuracy: 90+ CRI
 Power usage: 13 W
 Dimmable (see driver below)
 Wood grain and stone will vary
 Specifications subject to change



MATERIAL & FINISH OPTIONS

Tersus part # 03-136-

Wood Body	W
walnut (CM-001)	W
dark stained walnut (CM-002)	D
maple (CM-005)	M
Optional Face Material	
brushed aluminum (CM-012)	A
brushed rose gold (CM-046)	G
brushed brass (CM-047)	R
carrara marble (CM-078)	C
none (leave blank)	
Lamping	
2700 K LED	27
3500 K LED	35
Driver	
120-277 V AC input voltage	P1
0-10V dimming	
TRIAC and ELV dimming at 120 V AC only	
Includes	
frosted polymer (CM-024)	

J-box centered behind fixture

WOOD BODY AND OPTIONAL FACE MATERIALS

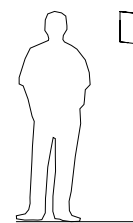
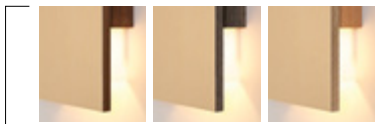

The Tersus is an example of the simplest form unlocking a myriad of design possibilities. The long reaching light pattern cast on the wall coupled with the numerous finishes and materials offered makes the Tersus well versed for all kinds of compositions and applications.

Nick Sheridan
Designer

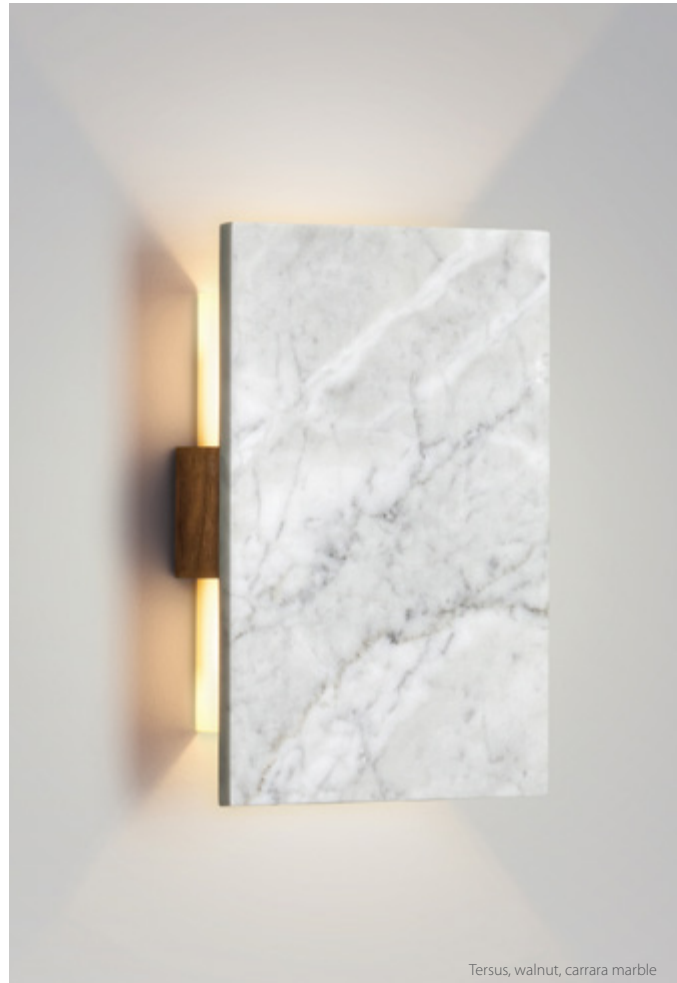

Tersus, walnut, carrara marble

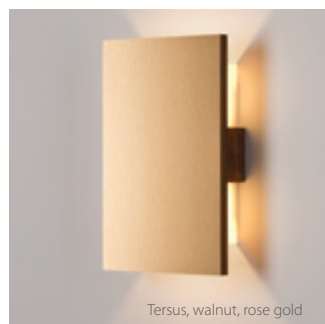

Tersus, walnut, rose gold

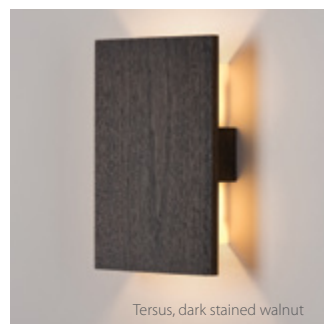

Tersus, dark stained walnut

Sedo
sconce

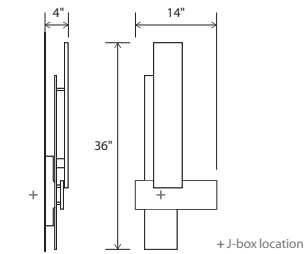

Dimensions: 36" x 14" x 4"
 Materials: solid wood, polymer
 Product weight: 6 lbs
 Light source: integrated LED
 Light output: 1130 Lumens (source)
 Light color: 2700 K or 3500 K
 Color accuracy: 90+ CRI
 Power usage: 13 W
 Dimmable (see driver below)
 ADA compliant hotel room signage with tactile numbering and corresponding braille available
 Wood grain will vary
 Specifications subject to change



MATERIAL & FINISH OPTIONS

Sedo part # 03-133-

Wood Body	W
walnut (CM-001)	W
dark stained walnut (CM-002)	D
Lamping	
2700 K LED	27
3500 K LED	35
Driver	
120-277 V AC input voltage	P1
0-10 V dimming	
TRIAC and ELV dimming at 120 V AC only	
Includes	
frosted polymer (CM-024)	



walnut (CM-001)



dark stained walnut (CM-002)



Sedo, walnut

The Sedo is composed of just three floating planes all kept parallel to the wall. This simple composition cloaks the light engine from view and filters the light as it is delivered far up and down the wall. It's this wall grazing and diffuser glow that gives the Sedo a strong architectural presence.

Nick Sheridan
Designer

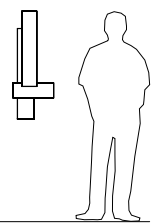

Emergency backup option available upon request, requires oversized J-box.



Ansa, distressed brass



Ansa, distressed brass



brushed aluminum brushed brass distressed brass oiled bronze

Ansa
sconce

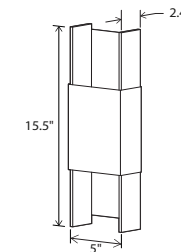

Dimensions: 15.5" x 5" x 2.4"
 Materials: metal, polymer
 Product weight: 3 lbs
 Light source: integrated LED
 Light output: 1130 Lumens (source)
 Light color: 2700 K or 3500 K
 Color accuracy: 90+ CRI
 Power usage: 13 W
 Dimmable (see driver below)
 Specifications subject to change



MATERIAL & FINISH OPTIONS

Ansa part # 03-137 -

Body

- brushed aluminum (CM-006) A
- brushed brass (CM-008) R
- distressed brass (CM-009) D
- oiled bronze (CM-010) Z

Lamping

- 2700 K LED 27
- 3500 K LED 35

120-277 V AC input voltage
 0-10V dimming
 TRIAC and ELV dimming at
 120 V AC only

Includes

frosted polymer (CM-024)

J-box centered behind fixture



brushed aluminum
(CM-006)



brushed brass
(CM-008)

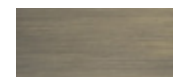

distressed brass
(CM-009)

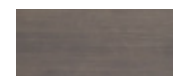

oiled bronze
(CM-010)

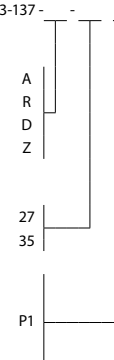

The Ansa is a simple form that has been detailed and executed without compromise. The robust metal collar broadly trains the light while the light diffusing blades closely attenuate the wash pattern on the wall, yielding a simple and sophisticated feel.

Nick Sheridan
 Designer

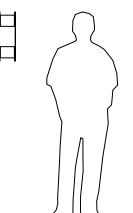

in collaboration with
DESIRON FRANK CARFARO
HAND CRAFTED AMERICAN FURNITURE

Fortis
sconce

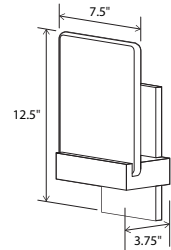

Dimensions: 12.5" x 7.5" x 3.75"
Materials: solid wood, metal, artisan glass option, marble option
Product weight: 10 lb
Light source: integrated LED
Light output: 565 Lumens (source)
Light color: 2700 K or 3500 K
Color accuracy: 90+ CRI
Power usage: 7 W
Dimmable (see driver below)
Wood grain, bubbles in glass, and stone will vary
Specifications subject to change



MATERIAL & FINISH OPTIONS

Fortis part # 03-170-

Metal Finish

- brushed brass (CM-008) R
- distressed brass (CM-009) D
- oiled bronze (CM-010) Z
- brushed aluminum (CM-006) A

Wood Finish

- walnut (CM-001) W
- dark stained walnut (CM-002) D

Diffuser

- artisan bubble glass (CM-059) B
- carrara marble (CM-078) C

Lamping

- 2700 K LED 27
- 3500 K LED 35

Driver

- 120 V AC input voltage TRIAC & ELV dimming P1
- 277 V AC input voltage 0-10V dimming P2

J-box centered behind metal plate



brushed brass (CM-008)



distressed brass (CM-009)

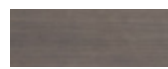

oiled bronze (CM-010)



brushed aluminum (CM-006)



walnut (CM-001)



dark stained walnut (CM-002)

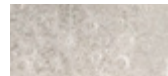

artisan bubble glass (CM-059)



carrara marble (CM-078)

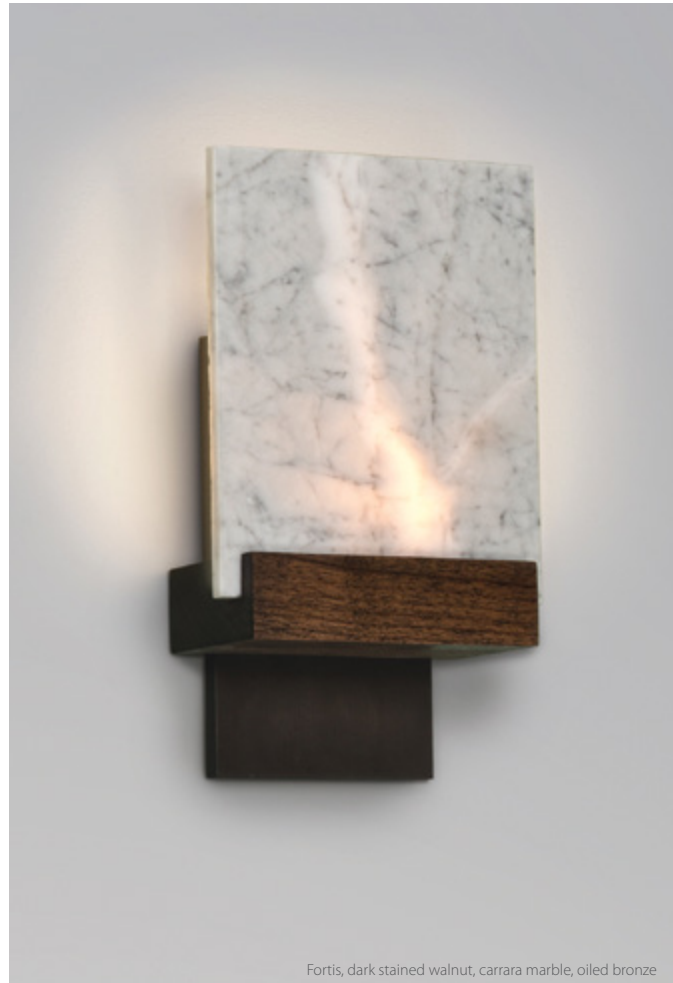

Fortis, dark stained walnut, carrara marble, oiled bronze



dark stained walnut, artisan glass, brushed brass



dark stained walnut, artisan glass, oiled bronze

The Fortis wall sconce is a great example of the collaborative design process. The initial concept from the New York based Desiron was refined over many iterations. We then worked with the local Southern California artisan glass company Siemon & Salazar to achieve a very specific bubbled glass lens that diffuses the light. It is a strong and sophisticated display of three elements: a piece of metal, a piece of wood, and a piece of glass all beautifully showcased in light.

Nick Sheridan
Co-Designer

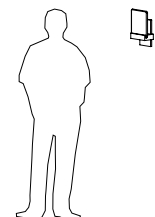

Clauco, walnut

The Clauco sconce showcases the beautiful natural walnut wood grain and sets it against the rigorous slits cut in each face as they wrap around the simple, clean shade form. A beautiful glow emanates from each slit, showing the striking rectilinear composition, in which all three sides are unique.

Nick Sheridan
Designer

Clauco
sconce

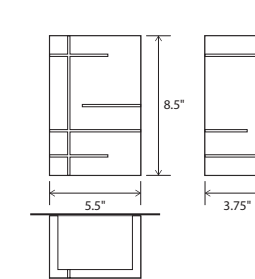

Dimensions: 8.5" x 5.5" x 3.75"
Materials: solid wood, polymer
Product weight: 4 lb
Light source: integrated LED
Light output: 1130 Lumens (source)
Light color: 2700 K or 3500 K
Color accuracy: 90+ CRI
Power usage: 13 W
Dimmable (see driver below)
Wood grain will vary
Specifications subject to change



MATERIAL & FINISH OPTIONS

Clauco sconce part # 03-150-

Wood Body

- walnut (CM-050) W
- dark stained walnut (CM-002) D

Lamping

- 2700 K LED 27
- 3500 K LED 35

- 120-277 V AC input voltage 0-10V dimming TRIAC and ELV dimming at 120 V AC only P1

Includes

- frosted polymer (CM-024)

J-box centered behind fixture

Also available in a pendant version, see page 41



walnut (CM-050)

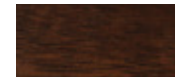

dark stained walnut (CM-002)

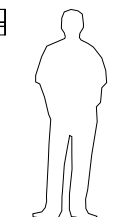

Cubo
bedside wall sconce/reading lamp hybrid

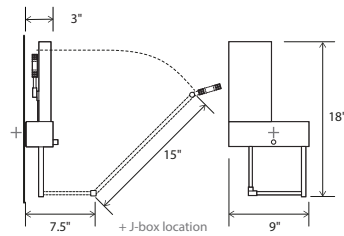

Dimensions: 18" x 9" x 3", 22.5" articulating arm
 Materials: solid wood, aluminum, polymer
 Product weight: 3 lb
 Full arm and light head articulation
 Light source: integrated LED
 Light output: 345 Lumens (source)
 Light color: 2700 K
 Color accuracy: 90+ CRI
 Power usage: 3.2 W
 Dimmable on fixture
 Input voltage: 12 V DC (adapter included)
 Hardwired and corded versions available
 Hardwired model includes an external power adapter (3" x 1.63" x 1.25")
 Requires space in J-box for included power adapter
 Wood grain will vary
 Specifications subject to change



OPTIONS

Cubo part # 03-110-

Direction
 left model L
 right model R

Installation
 hardwired* H
 corded C

Includes
 solid walnut body (CM-001)
 aluminum arms (CM-006)
 frosted polymer shade

Alternate voltage / plug styles available

*Hardwired installation uses a standard 3" round plaster ring and requires room in the j box for the included external power supply. Get installation instructions at www.cernogroup.com

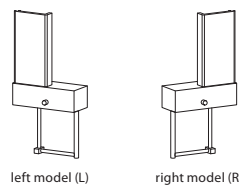

left model (L) right model (R)



Cubo, right model

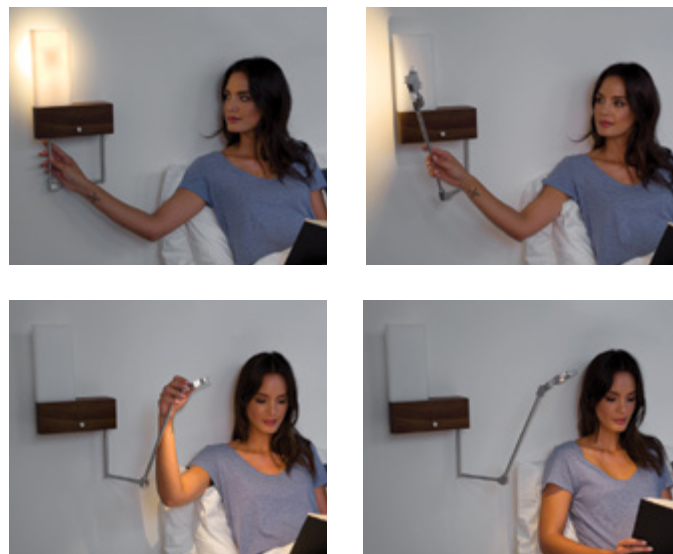

Necessity is the mother of invention, and in this case illuminated activities in bed need highly controlled light — provided here without compromise, while still delivering a simple, clean wall sconce with ambient light — all in one fixture! — and it leaves your nightstand clutter free! Now that is modern.

Nick Sheridan
 Designer

Libri
bedside sconce reading light

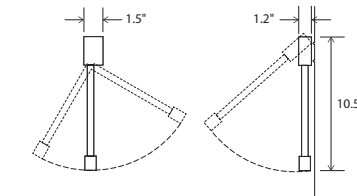

Dimensions: 10.5" x 1.5" x 1.2"
 Materials: aluminum, polymer, optional solid wood mounting
 Product weight: 1 lb
 Light source: integrated LED
 Light output: 160 Lumens (source)
 Light color: 2700 K
 Color accuracy: 90+ CRI
 Power usage: 2 W
 Automatic ON/OFF when arm is pulled away from wall
 Specifications subject to change



MATERIAL & FINISH OPTIONS

Libri part # 03-160-

Direction
 left model L
 right model R

Finish
 brushed aluminum (CM-006) A
 white (CM-060) Y

Installation
 corded (plug-in) C
 hardwired* H

Alternate voltage / plug styles available
 J-box centered behind fixture

DIRECTION

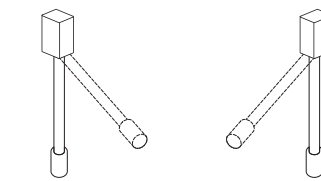

INSTALLATION

*Hardwired installation requires room in the J-box for the included external power adapter (2" x 1" x 1.25"). Typically mounting kit is used. See mounting options on this page



Libri, right model

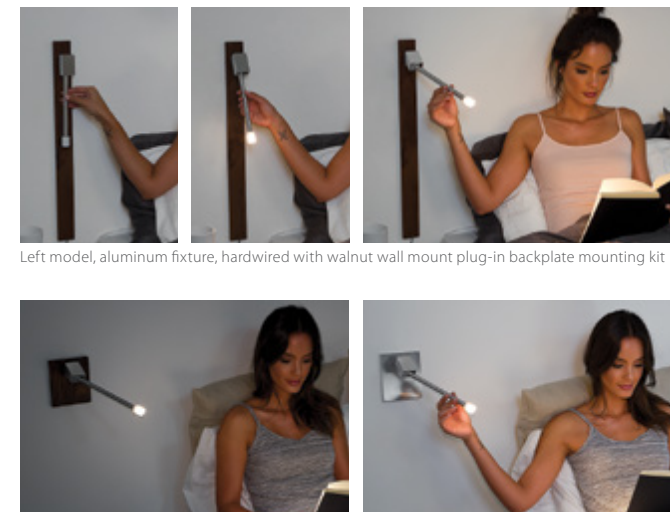

Left model, aluminum fixture, hardwired with walnut J-box plug-in backplate mounting kit
 Left model, aluminum fixture, hardwired with aluminum J-box plug-in backplate mounting kit

MOUNTING OPTIONS
 Mounting kits are sold separately from the Libri fixture.
 No Mounting kit is required if the Libri fixture is to be installed using the Direct Mount option.

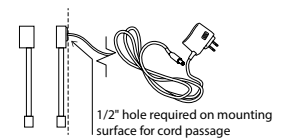

Direct Mount
 Direct mount option is used when mounting directly to a headboard. There is no backplate and the cord must be fed through a hole in the headboard directly behind where the fixture is mounted and plugged into a wall outlet using the included AC adapter.

Libri Mounting Kit
sconce backplate

J-box Backplate: Mounting Kit (3)
 J-box backplate is typically used when mounting to a J-box. Hardwired installation requires room in the J-box for the included external power adapter (2" x 1" x 1.25").

Wall Mount Plug-in Backplate: Mounting Kit (1, 2)
 Wall mount plug-in backplate is used when mounting directly to the wall and plugging into a wall outlet. The wall mount is an elongated rectangle that allows the cord to exit discreetly below the fixture.

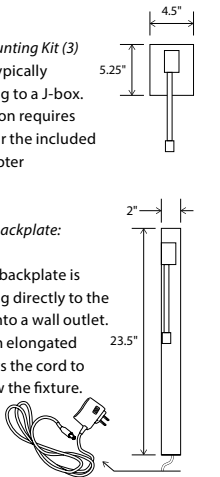

MOUNTING KIT OPTIONS

Mounting Kit Part # 03-160-10-

Direction
 wall mount plug-in, left 1
 wall mount plug-in, right 2
 J-box backplate 3

Finish
 brushed aluminum (CM-006) A
 walnut (CM-001) W
 white (CM-060) Y

The Libri is about function and ease: an extremely articulate directional task light in a discrete and sturdy form that is very intuitive to use.

Nick Sheridan,
 Designer



Levo, walnut

REDDYMADE ARCHITECTURE AND DESIGN



Levo, right model

Levo
bedside wall sconce/reading
lamp hybrid with USB charger

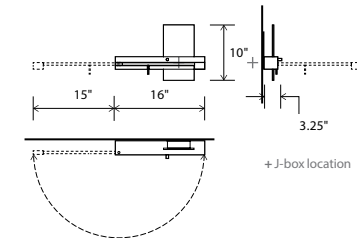

Dimensions: 10" x 16" x 3.25"
 Materials: solid wood, aluminum, polymer
 Product weight: 3 lb
 Light source: 2x integrated LED
 Static sconce light + swim arm with rotating head light
 Light output of static sconce source: 565 Lumens (source)
 Light output of swing arm source: 160 Lumens (source)
 Light color: 2700 K
 Color accuracy: 90+ CRI
 Power usage: 20 W total (10 W USB charger)
 USB charge current: 2 A
 Fully dimmable static sconce light with Automatic ON/OFF swing arm light source
 Swing arm light is not dimmable
 Input voltage: 12 V DC (adapter included)
 Hardwired and corded versions available
 Hardwired model includes an external power supply (2.75" x 1.63" x 1.13")
 Requires space in J-box for included power adapter
 Alternate voltage/plug styles available
 Hardwired adapter input voltage: 120-277 V AC
 Corded adapter input voltage: 120 V AC
 Wood grain will vary
 Specifications subject to change



MATERIAL & FINISH OPTIONS

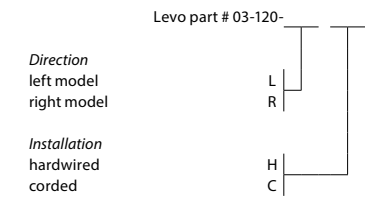

Includes
 solid walnut body (CM-001)
 brushed aluminum (CM-006)
 frosted polymer (CM-024)

Alternate voltage / plug styles available

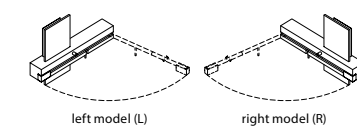

Levo Shelf Option



Levo, right model with shelf option

The introduction of the optional shelf for the Levo increases the utility of this fixture without compromising any aspect of the design. The shelf provides a perfect place to rest your phone or tablet while charging it. It is important to note that shelf is purchased separately from the Levo and can be retrofitted on existing Levos.

MATERIAL & FINISH OPTIONS

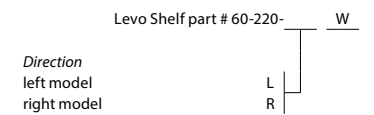

Includes
 solid walnut shelf (CM-001)
 brushed aluminum (CM-006)

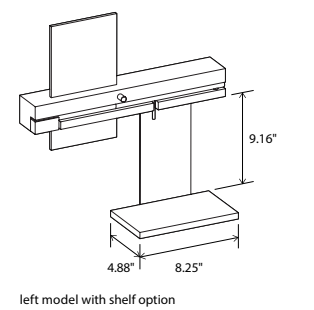

left model with shelf option

The goal for the Levo was to create a bedside wall fixture with great task lighting articulation that was intuitive enough to be used without prior knowledge of the fixture: all the while making it slender, sexy, and very robust.

Nick Sheridan,
 Designer

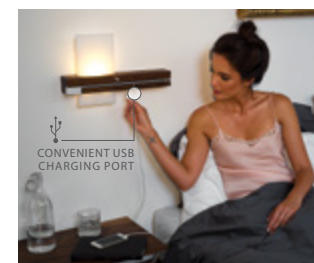



Table



Forma

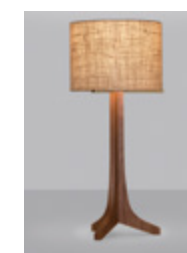

Nauta



Silva



Macto

in collaboration with
DESIRON FRANK CARFARO
HAND CRAFTED AMERICAN FURNITURE

Forma Table
desk/table

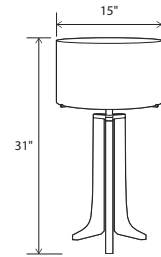

Dimensions: 15" Ø shade, 31"
Materials: solid wood, aluminum, fabric shade
Product weight: 10 lb
Light source: medium base E26 socket
Lamping: E26 base, type A lamp, 60 W max
Input voltage: 120 V AC max
Dimmable on fixture
Wood grain will vary
Specifications subject to change

Included dimmable LED A19 bulb
Light output: 800 Lumens (source)
Light color: 2700 K
Color accuracy: 90+ CRI
Power usage: 11 W

MATERIAL & FINISH OPTIONS

Forma Table part # 02-150-

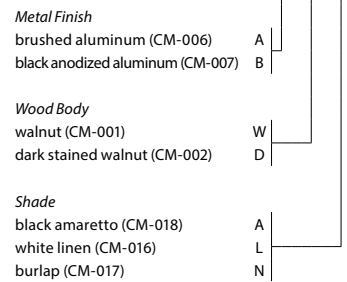

Alternate voltage / plug styles available
Also available as a Floor Lamp, See page 16



Forma Table, walnut, black anodized aluminum, white linen



Being our most traditional fixture, Frank Carfaro and I worked to design a piece that embraced both Cerno and Desiron's aesthetic, without deviating too much from either brand's design language. I am really pleased with the fluidity, posture and scale we achieved with the Forma table, and its likeness to the Forma floor lamp.

Nick Sheridan
Co-Designer

Nauta Table
desk/table

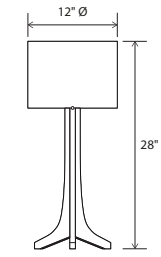

Dimensions: 12" Ø, 28"
Materials: solid wood, aluminum, fabric shade
Product weight: 3 lb
Light source: medium base E26 socket
Lamping: E26 base, 60 W max
Input voltage: 250 V AC max
Includes 8' clear silver cord with white plug
On/Off rocker switch on socket
Wood grain will vary
Specifications subject to change

Included dimmable LED A19 bulb
Light output: 800 Lumens (source)
Light color: 2700 K
Color accuracy: 90+ CRI
Power usage: 11 W

MATERIAL & FINISH OPTIONS

Nauta Table part # 02-160-

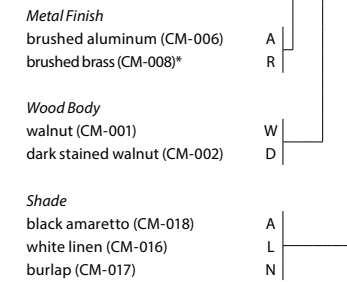

*Brass shade support arms feature wood plug in end of arm

in collaboration with
DESIRON FRANK CARFARO
HAND CRAFTED AMERICAN FURNITURE



walnut, brushed brass, burlap

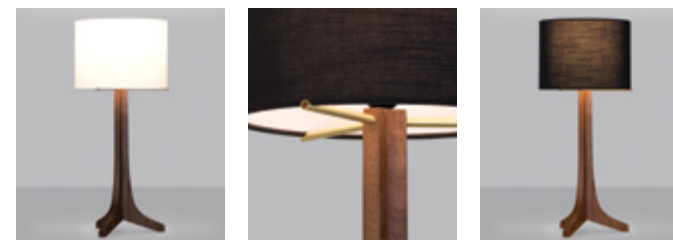

Efficiency and simplicity guided the design process for the Nauta table lamp. We designed the Forma several years ago with Frank Carfaro of Desiron, which profoundly influenced the Nauta's form. Our goal was to distill the Forma design without compromising it. The Nauta is clean, modern, and priced competitively.

Nick Sheridan
Designer

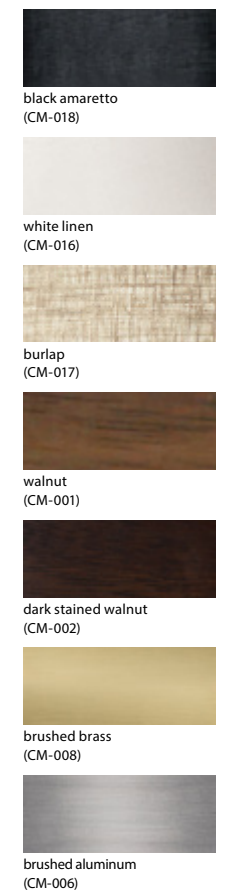

Silva
desk/table

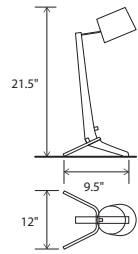

Dimensions: 12" x 9.5", 21.5"
 Materials: solid wood, aluminum, bent shade
 Articulating head
 Product weight: 2 lb
 Light source: integrated LED
 Light output: 565 Lumens (source)
 Light color: 2700 K
 Color accuracy: 90+ CRI
 Power usage: 7 W
 Input voltage: 12V DC (adapter included)
 White braided cord
 Dimmable on fixture
 Wood grain will vary
 Specifications subject to change



MATERIAL & FINISH OPTIONS

Silva part # 02-100- A

- | | |
|------------------------------|---|
| Metal Finish | A |
| brushed aluminum (CM-006) | |
| Wood Body | W |
| walnut (CM-001) | |
| dark stained walnut (CM-002) | D |
| Bent Shade | B |
| beech wood veneer (CM-019) | |
| ebony eco veneer (CM-020) | E |
| white linen (CM-058) | L |

Alternate voltage / plug styles available
 Also available in two larger versions

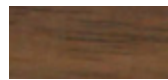

walnut (CM-001)



dark stained walnut (CM-002)



beech wood veneer (CM-019)



ebony eco veneer (CM-020)



white linen (CM-058)



Silva Table, walnut, white linen



dark stained walnut, ebony eco veneer

walnut, white linen

dark stained walnut, beech wood veneer

The structural connection between metal and wood was the inspiration here, where the fixture's stance is only strengthened by gravity. The tri-leg base finds stability on uneven surfaces and allows the cord to exit discreetly and effectively. It feels signature and iconic while still keeping a clean and timeless modern aesthetic.

Nick Sheridan
 Designer

Macto
desk/task

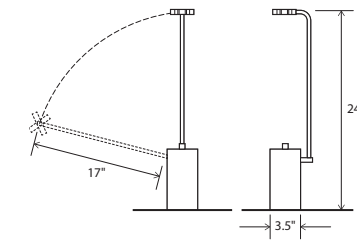

Dimensions: 3.5" x 3.5", 17" arm reach
 Materials: solid wood, aluminum arm
 Product weight: 5 lb
 Light source: integrated LED
 Light output: 345 Lumens (source)
 Light color: 2700 K
 Color accuracy: 90+ CRI
 Power usage: 3.2 W
 Input voltage: 12V DC (adapter included)
 Black braided cord
 Dimmable on fixture
 Wood grain will vary
 Specifications subject to change



walnut (CM-001)



dark stained walnut (CM-002)

MATERIAL & FINISH OPTIONS

Macto part # 02-140- A

- | | |
|------------------------------|---|
| Metal Finish | A |
| brushed aluminum (CM-006) | |
| Wood Body | W |
| walnut (CM-001) | |
| dark stained walnut (CM-002) | D |

Alternate voltage / plug styles available



Macto, walnut

The Macto showcases the breathtaking natural beauty of the solid walnut base. Only in a truly solid piece of wood can you see the fascinating way that the grain changes as it passes from face to face. Great reach and articulation make the Macto an extremely functional and versatile fixture: while its form and composition are kept remarkably simple.

Nick Sheridan
 Designer

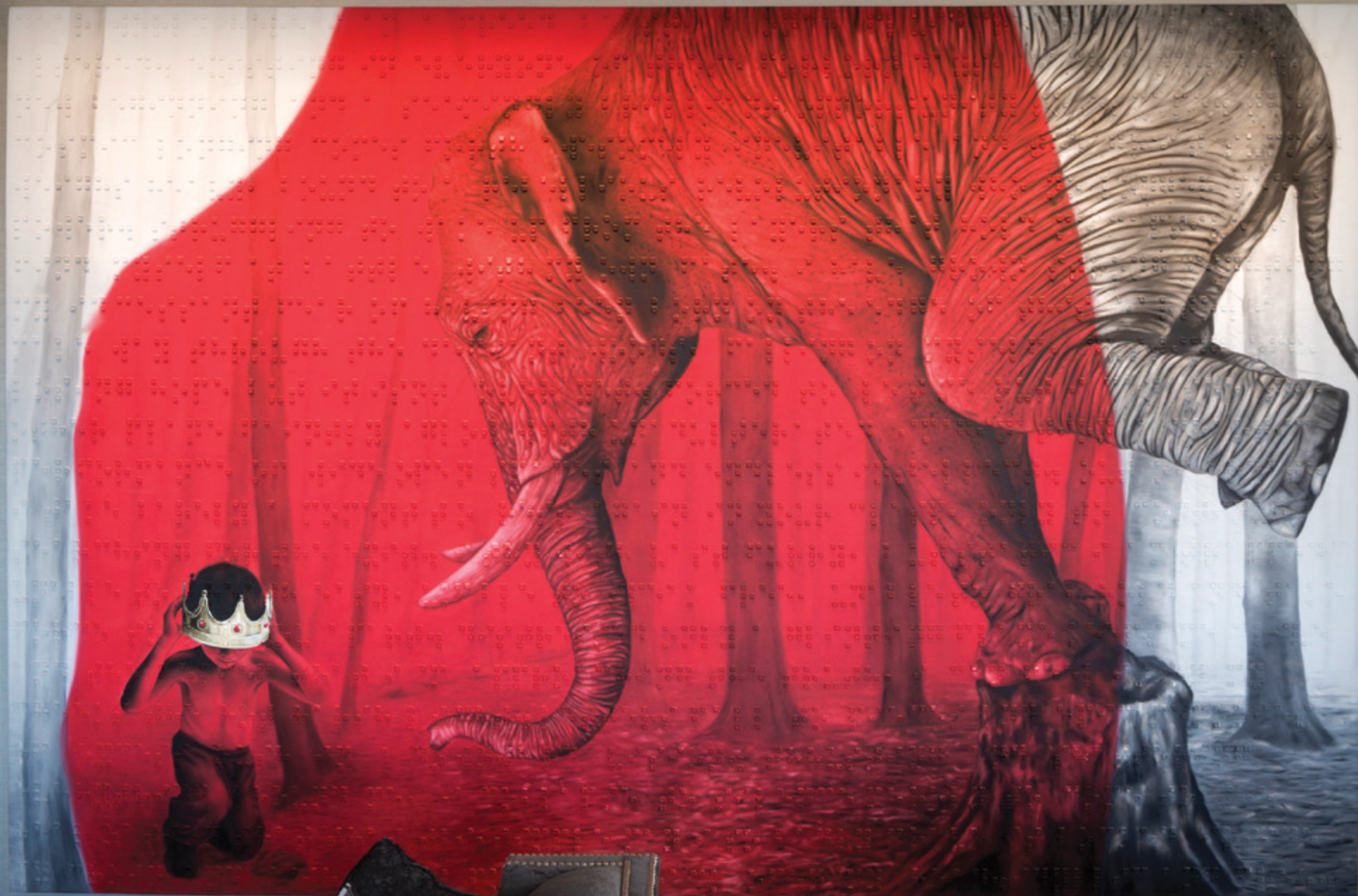

Artist: Roy Nachum

STACI RUIZ LIGHTING CONSULTANT PHOTO BY ARI BURLING



Guy Rose, Impressionist

Revelite AL
art light

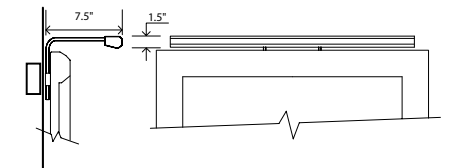

The Revelite AL brings art to life. A challenge resolved by a slim luminaire that discreetly and evenly illuminates an artwork surface with beautiful color rendering accuracy.

CUSTOMIZED

Each AL is custom built and factory calibrated for an artwork's specific dimensions, distributing even illumination across the full width and height of the surface.

HIGH COLOR ACCURACY

To accurately reflect the artist's vision, the LED light source was designed to provide full color spectrum lighting with a color rendering index over 90 and an R9 value of 83.

ART SAFE

Revelite AL's LED technology provides a much safer alternative to legacy sources that emit excessive and damaging UV and heat.

LOW PROFILE

The minimal form virtually disappears against the frame or wall and pairs well with various styles of art, including contemporary, photographs behind glass and more traditional works.

VISIT

www.revelite.com for detailed specifications and options.

US Patent # 7,070,293 and 9,134,004.

Other US and International Patents Pending.

These lights revealed subtleties in paintings you just don't see with ordinary lights. I think we are seeing, truly for the first time, what the artist really wanted us to see.

Pat Trenton, Ph.D.

Art expert, curator and writer



Wolfgang Bloch, Contemporary



Tom Lamb, Photograph (behind glass)

Accessories



Motus Swing Arm Bracket accessory

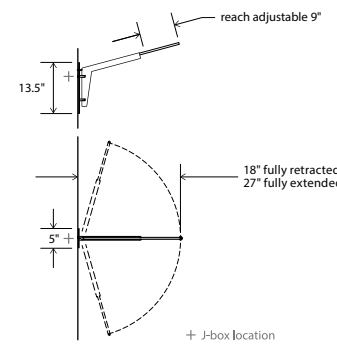





Dimensions: 18.38" x 5" x 26.8"
 Materials: solid wood, metal
 Product weight: 3 lb
 Max suspension weight: 5 lb
 Swing arm length can be adjusted from 18" to 27"
 Max drop length from tip of extended arm to top of pendant is 36"
 Swing arm rotation has adjustable resistance in pivot hinge
 Wood grain will vary
 Specifications subject to change
 Patent No. : US D846,180 S



MATERIAL & FINISH OPTIONS

Motus Swing Arm Bracket part # 60-210-

 brushed aluminum (CM-006)	 textured black powder coat (CM-049)
 walnut (CM-001)	 dark stained walnut (CM-002)

Metal Finish
 brushed aluminum (CM-006)
 textured black powdercoat (CM-049)

Wood Body
 walnut (CM-001)
 dark stained walnut (CM-002)

Please see the Talea on page 51

How it works: Build your own fixture

Pick one of the pendants listed below and pair it with the Motus Swing Arm Bracket for a unique and versatile light fixture. To order, you will need to select a SKU for the pendant that you choose and a SKU for the Motus Swing Arm Bracket. The SKU builder for the Motus Swing Arm Bracket is above, and the SKU builders for the pendants are located on their respective tear sheets.



Canopy Accessories



Multi-Point Round Canopy
 For 3 accent pendants

Dimensions: 12"Ø, 1.25" H

MATERIAL & FINISH OPTIONS

12" Round Canopy part # 60-120-R

Finish
 brushed aluminum (CM-006)
 black anodized (CM-007)

Multi-Point Linear Canopy
 For linear pendants or 2 or 3 accent pendants

Dimensions: 20.6" x 4", 1.3" H

MATERIAL & FINISH OPTIONS

Multi-Point Linear Canopy part # 60-130-

Finish
 brushed aluminum (CM-006)
 black anodized (CM-007)

Number of Holes
 2 Holes (linear pendant) leave blank
 3 Holes (pendant cluster)

Wood Canopy Cover
 Fits over linear canopies except for Camur canopy (Camur wood canopy is on page 23)

Dimensions: 21" x 4.6", 1.75" H

MATERIAL & FINISH OPTIONS

Wood Canopy Cover part # 60-130-005

Finish
 walnut (CM-001)
 dark stained walnut (CM-002)





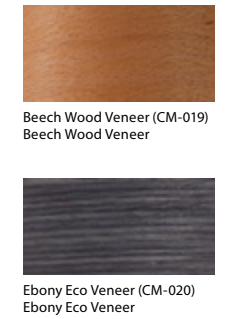



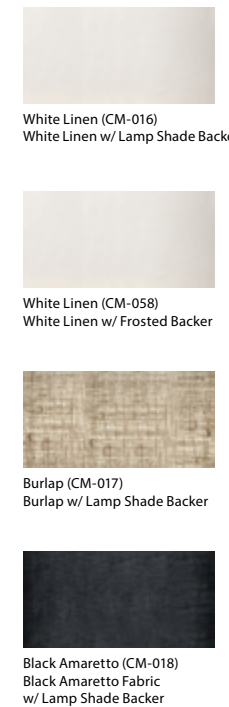

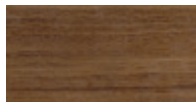

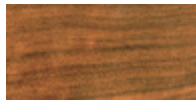

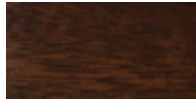

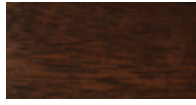
Number of Holes
 2 Holes (linear pendant) leave blank
 3 Holes (pendant cluster)

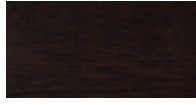
Hard Surface Shade



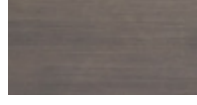

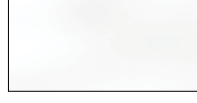
Fabric Shade





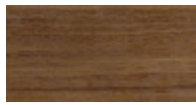
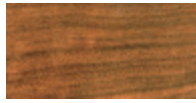
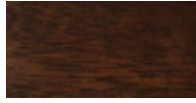
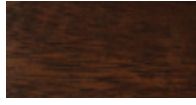
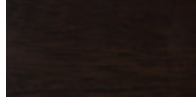

	Metal	Wood
Brushed Aluminum (CM-006) Brushed Aluminum		
Brushed Aluminum (CM-012) Brushed Anodized Aluminum Veneer		
Black Anodized Aluminum (CM-007) Black Anodized Aluminum		
Brushed Rose Gold (CM-046) Brushed Rose Gold Anodized Aluminum Veneer		
Brushed Brass (CM-047) Brushed Brass Anodized Aluminum Veneer		
Distressed Brass (CM-009) Distressed Brass - Patina		
Brushed Brass (CM-008) Brushed Brass		
Oiled Bronze (CM-010) Oiled Bronze - Patina		
Textured Black Powdercoat (CM-049) Textured Black Powdercoat		
Textured White Powdercoat (CM-060) Textured White Powdercoat		
Gloss White (CM-054) White Powdercoat Aluminum Sheet		

Wood

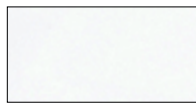
	Walnut (CM-001) Solid Oiled Walnut
	Walnut (CM-055) Oiled Walnut Veneer
	Dark Stained Walnut (CM-002) Solid Dark Stained Oiled Walnut
	Dark Stained Walnut (CM-056) Dark Stained Oiled Walnut Veneer
	Double Dark Stained Walnut (CM-048) Solid Lacquered Double Dark Stained Walnut
	Maple (CM-005) Solid Oiled Maple
	White Washed Oak (CM-095) Solid White Washed Oak

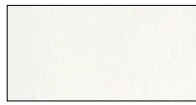
Polymer

	Frosted Polymer (CM-051) Frosted White Polycarbonate
	Frosted Polymer (CM-057) Frosted Polycarbonate
	Frosted Polymer (CM-024) Frosted Acrylic
	Polymer (CM-052) Natural Polyethylene

Stone

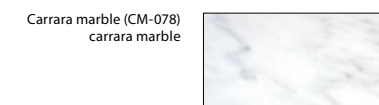

Artisan Bubble Glass

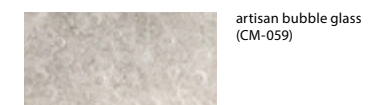

⚠️ **WARNING.** California Proposition 65 Warning for California Consumers. This product can expose you to chemicals including wood dust and lead which are known to the State of California to cause cancer or birth defects or other reproductive harm. For more information go to www.P65Warnings.ca.gov

cerno®

D E S I G N E D A N D M A D E I N C A L I F O R N I A

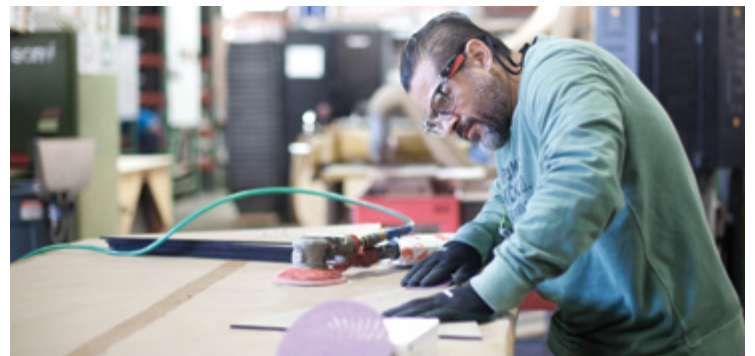

cerno®
DESIGNED AND MADE IN CALIFORNIA

CERNO, 1751 MCGAW AVE, IRVINE, CA 92614 | 949.715.1534 | WWW.CERNOGROUP.COM